



Vehicle Access Control  
Pedestrian Access Control  
Safety & Security Equipment

T: +61 7 3205 1123

[www.rotech.com.au](http://www.rotech.com.au)

e: [info@rotech.com.au](mailto:info@rotech.com.au)

## Beninca B17 Sliding Gate Operator Instructions (V10/25)



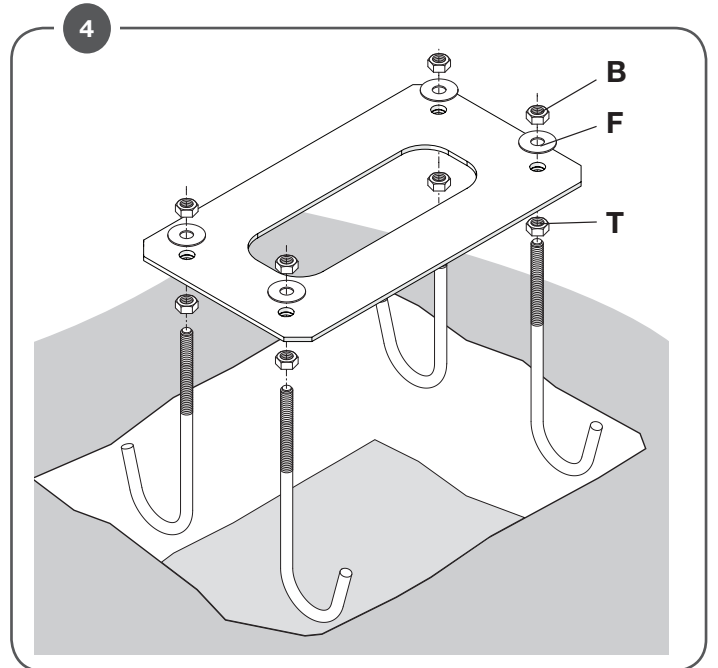
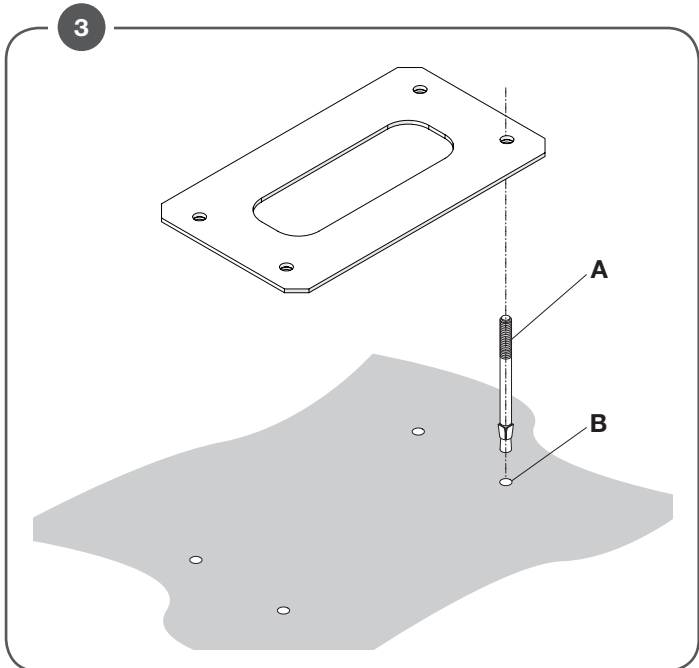
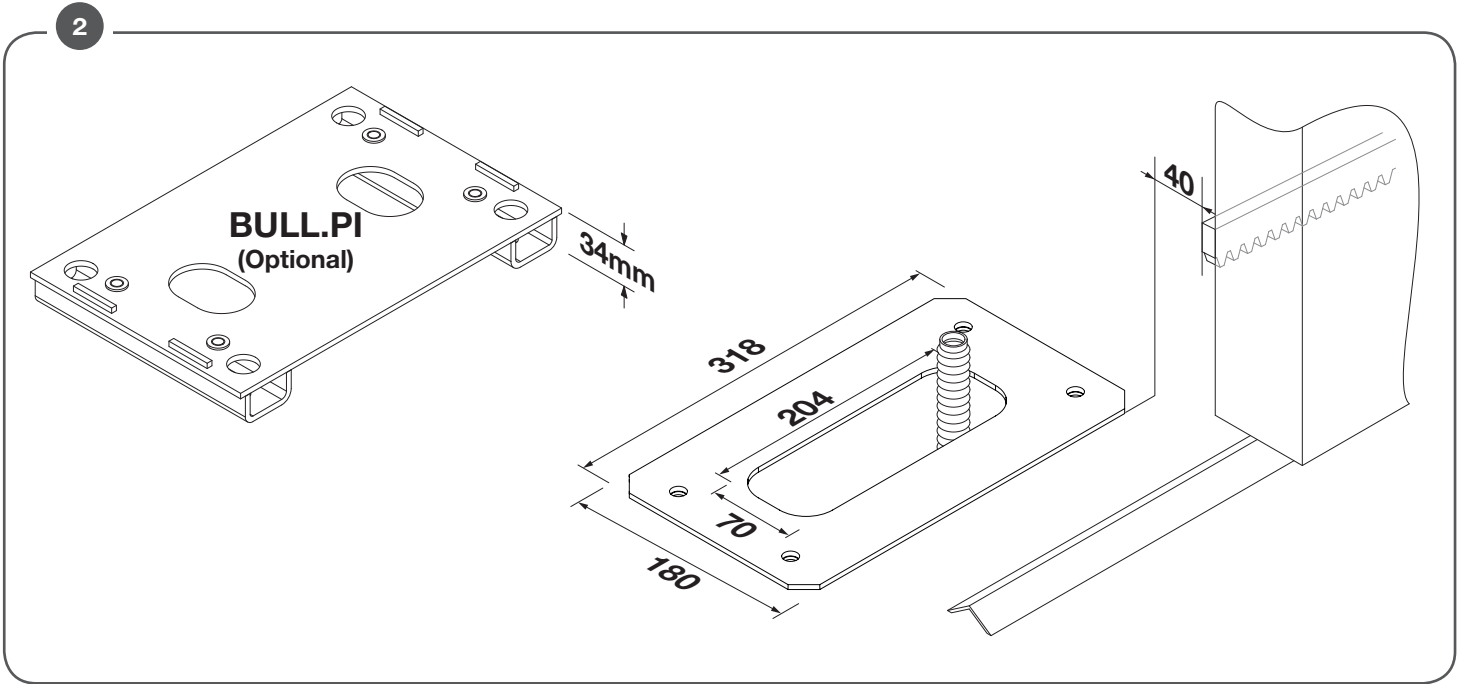
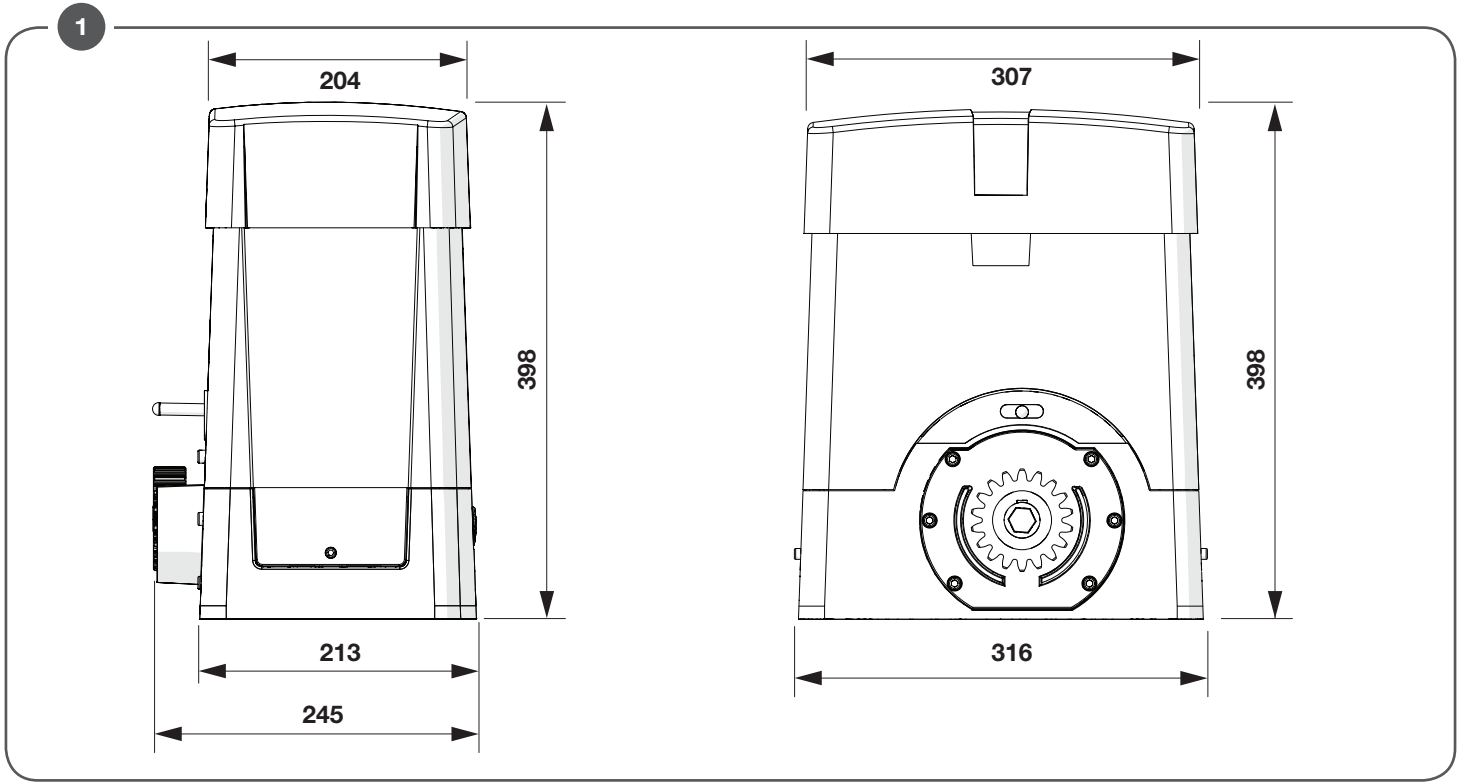

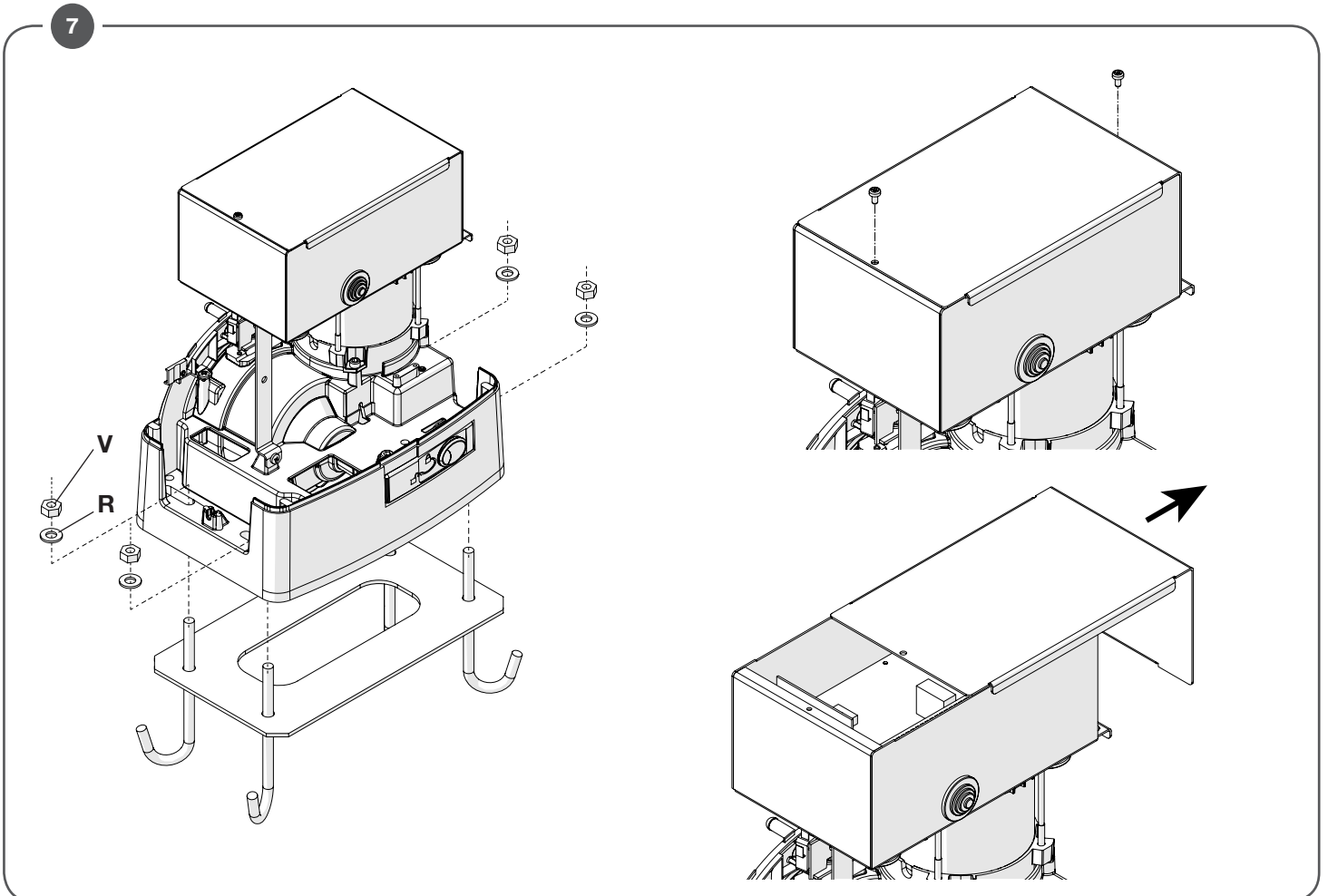
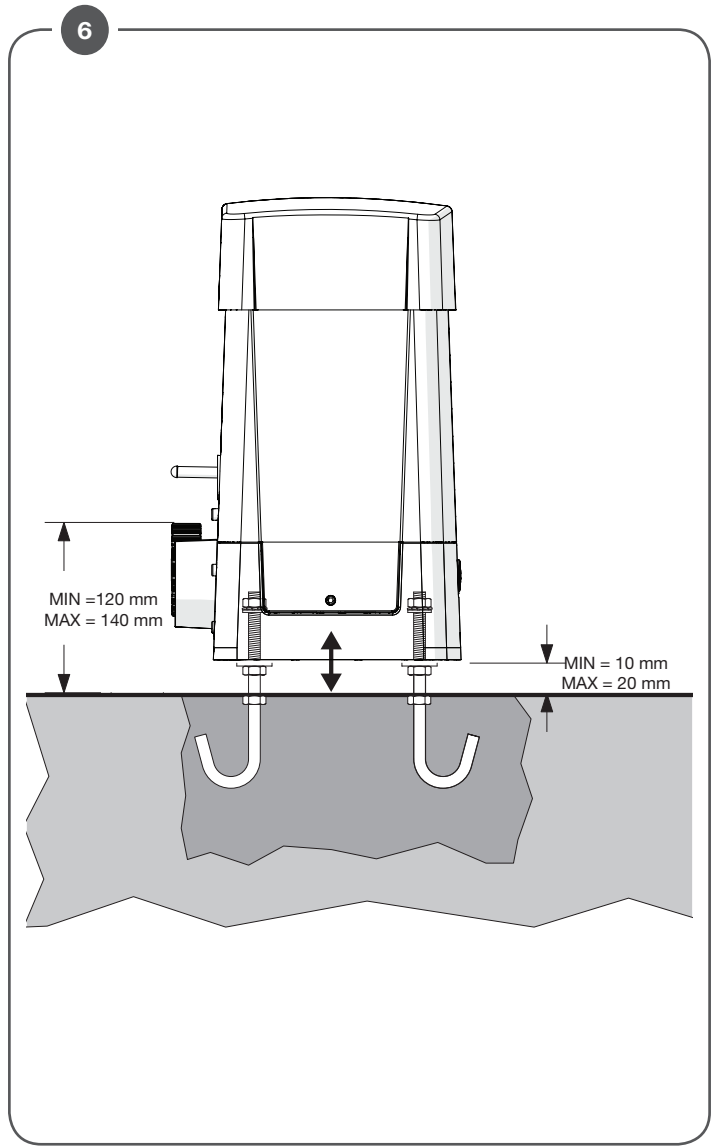
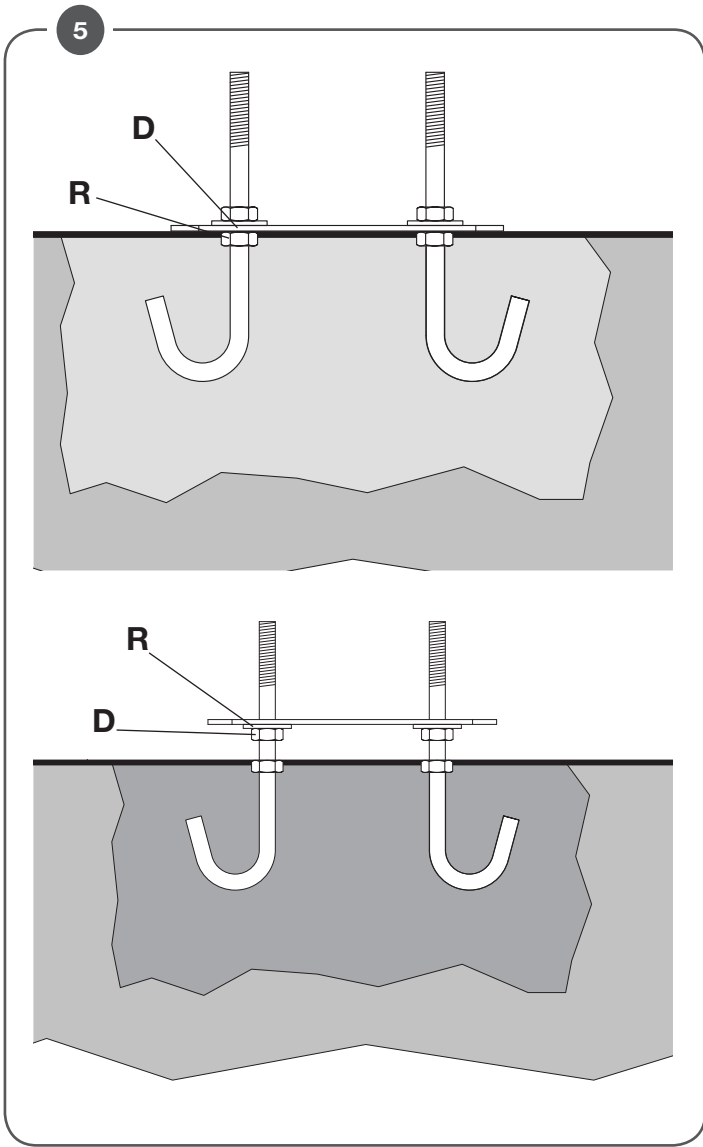

8

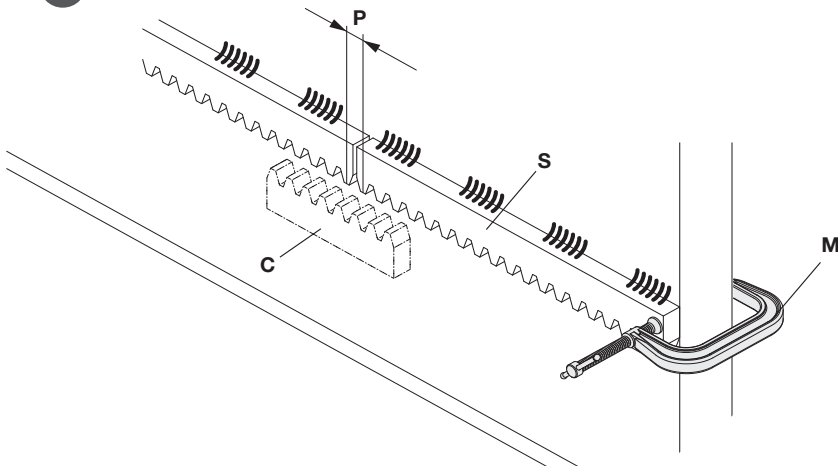

9

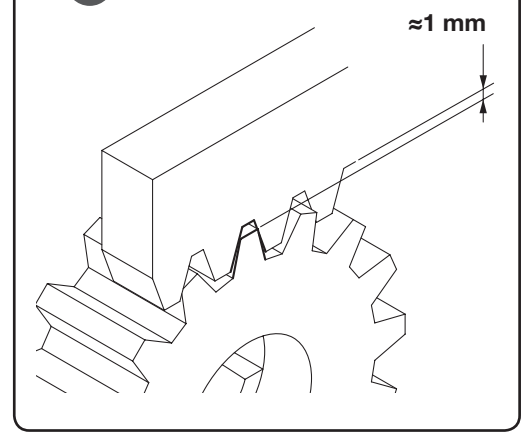

10

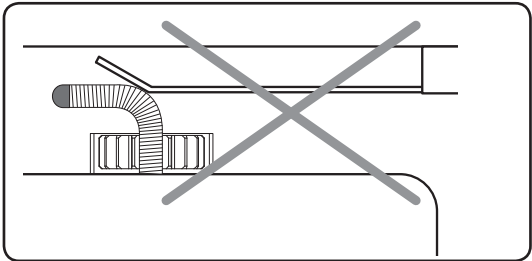
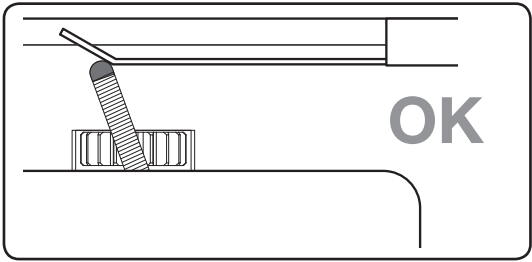
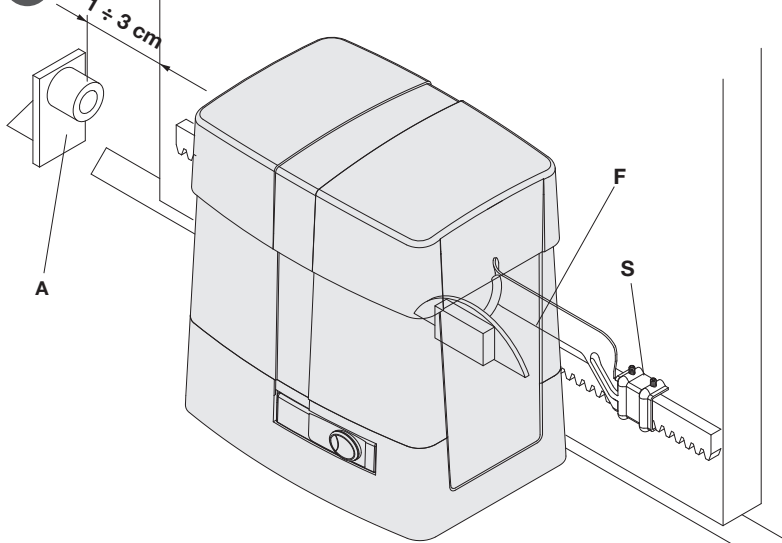

11

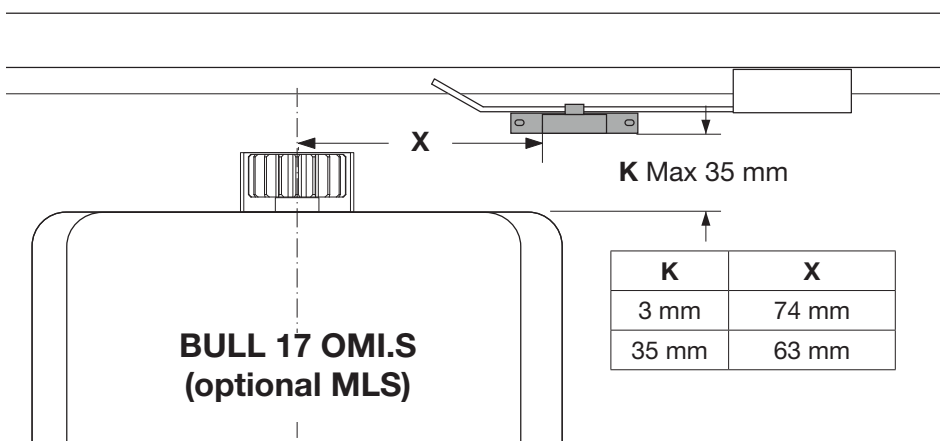
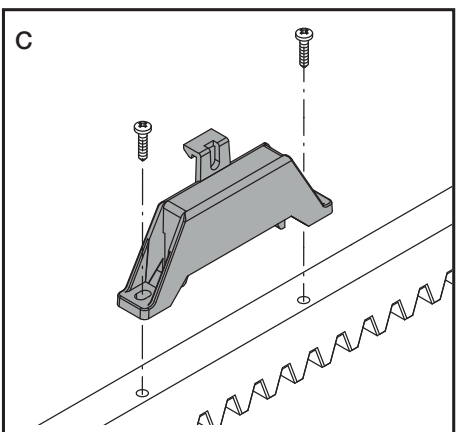
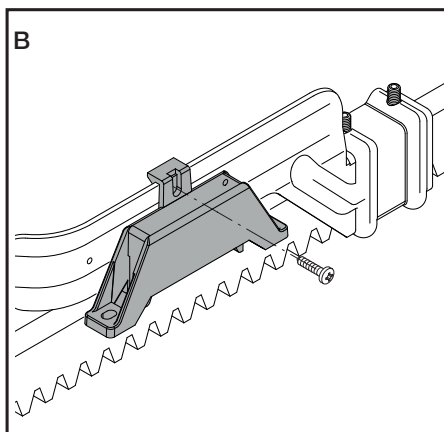
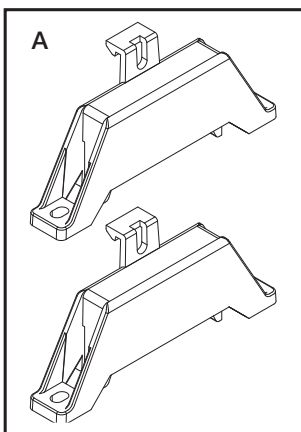

**K Max 35 mm**

K	X
3 mm	74 mm
35 mm	63 mm

**BULL 17 OMI.S**  
(optional MLS)

12

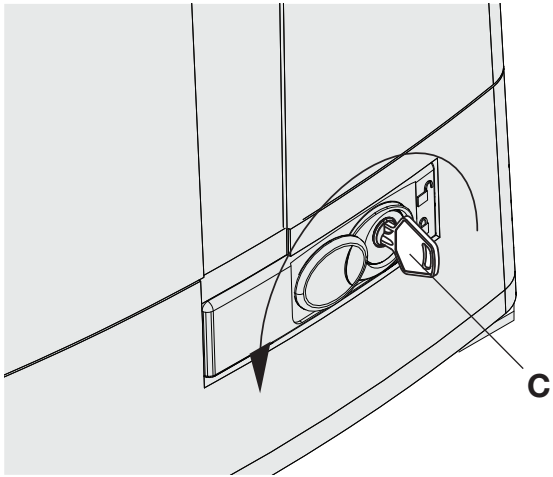

13

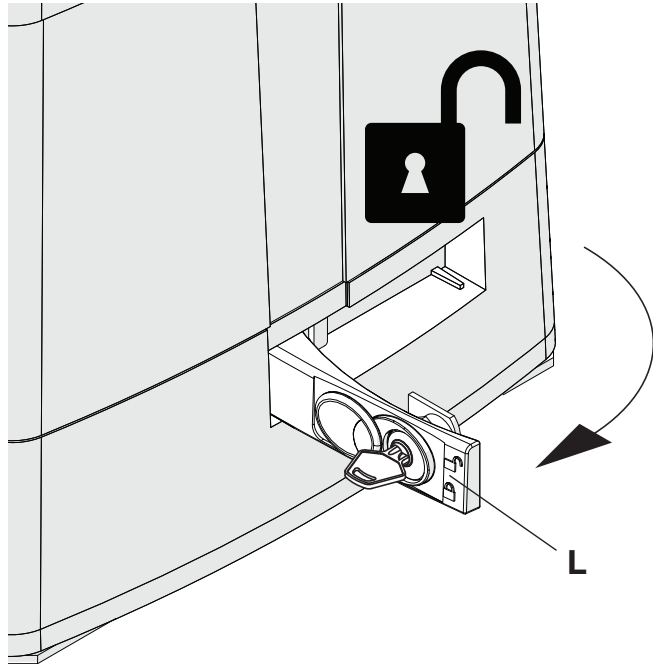

14

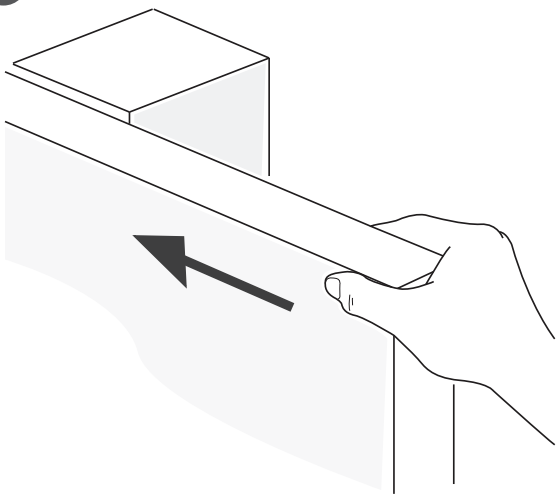

BAR

15

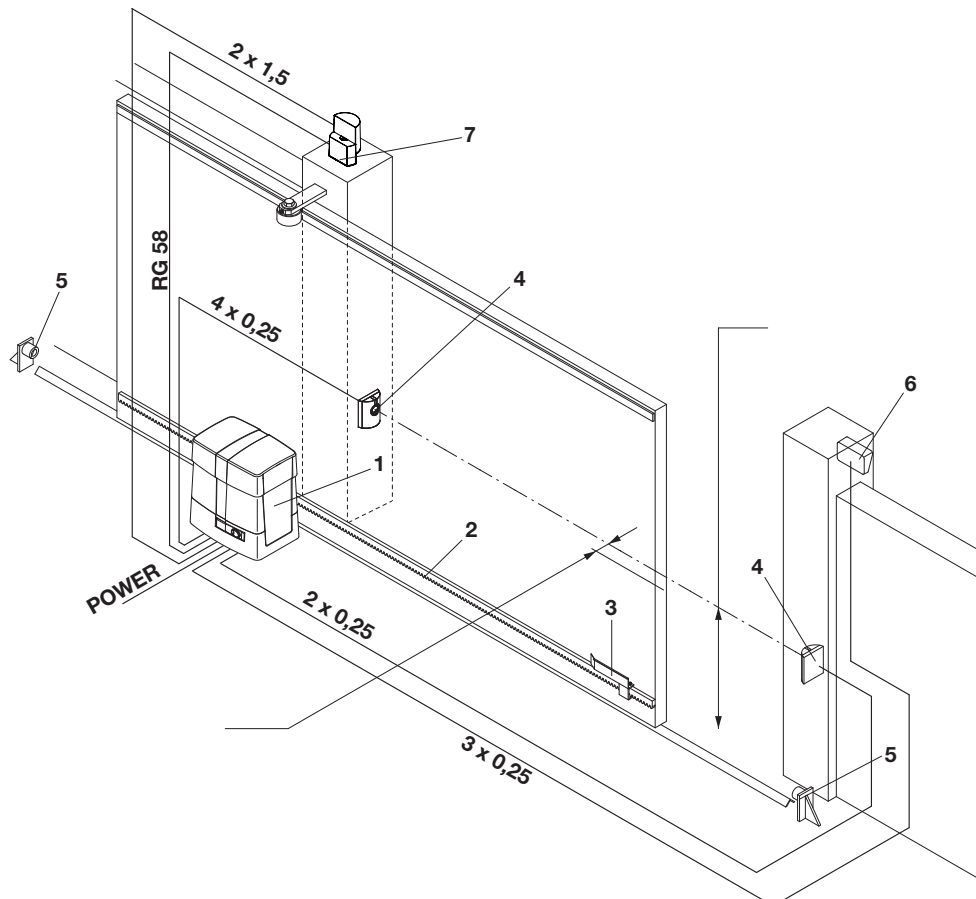

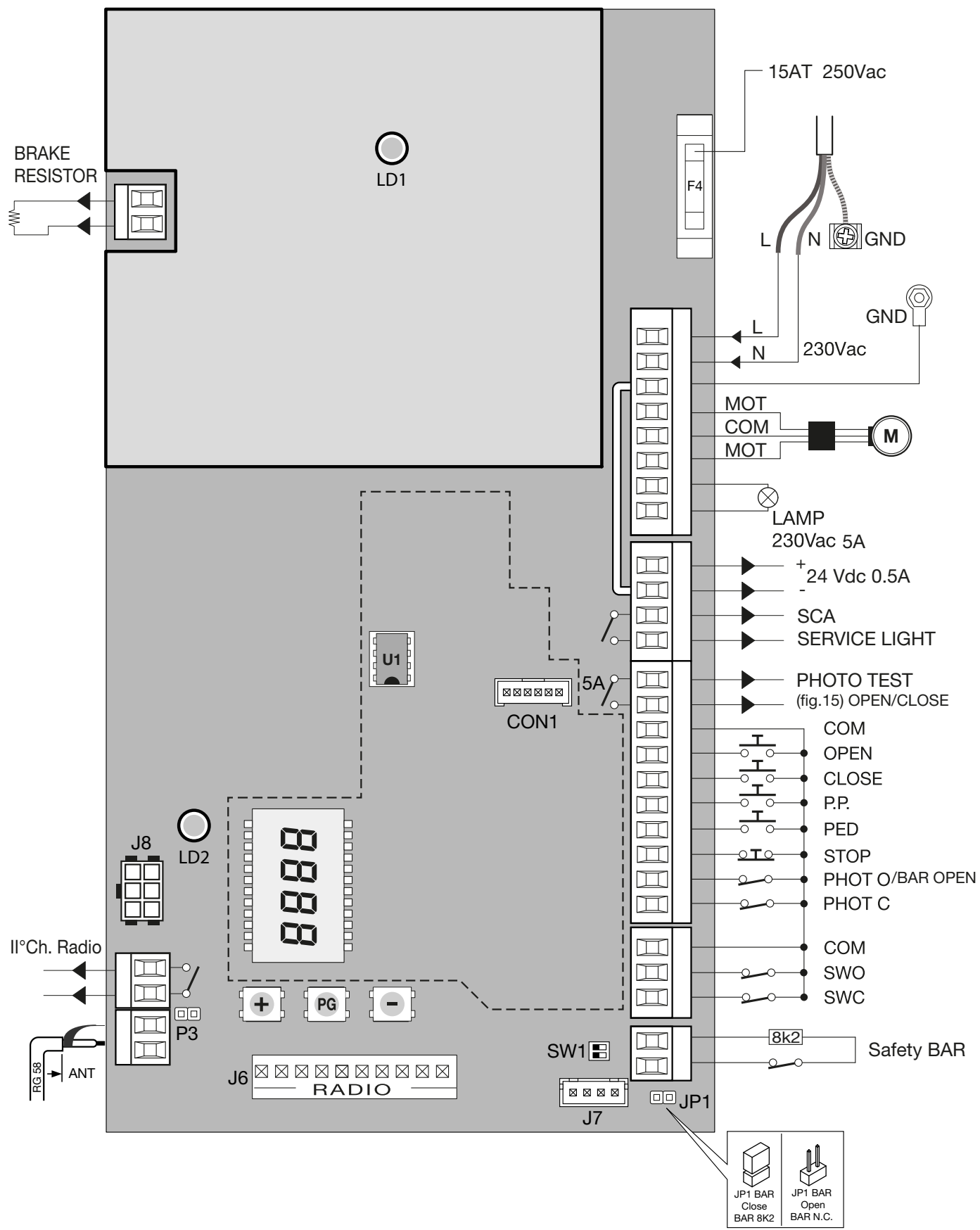

17

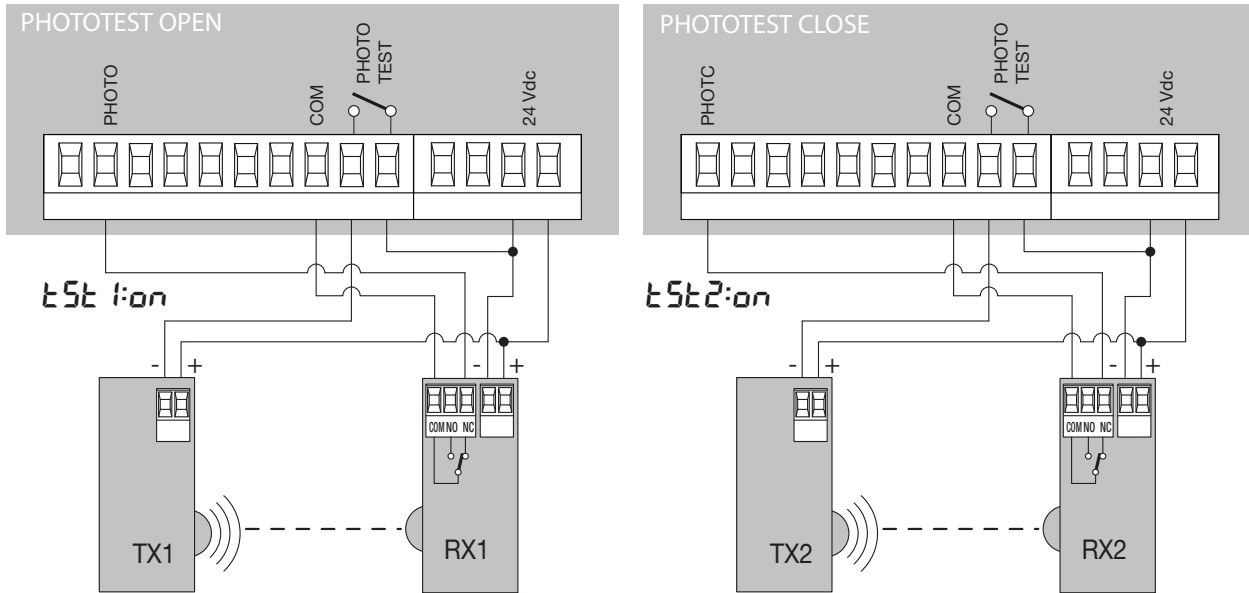

18

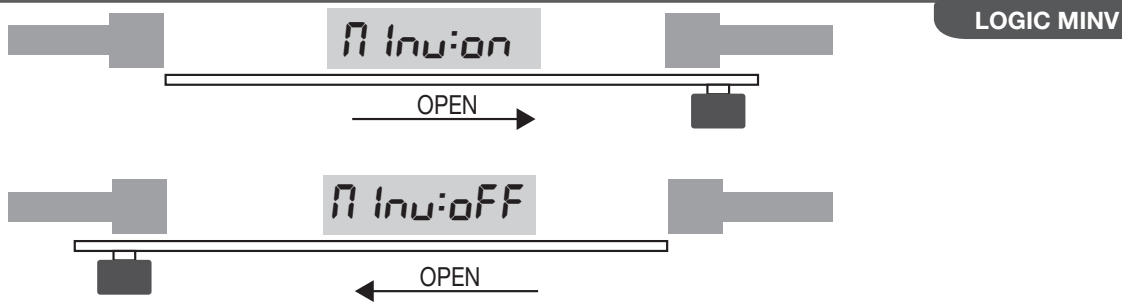

19

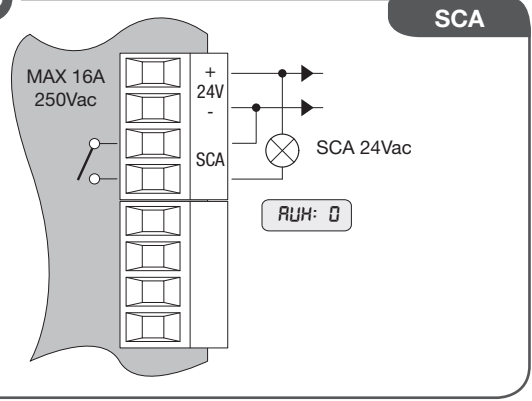

20

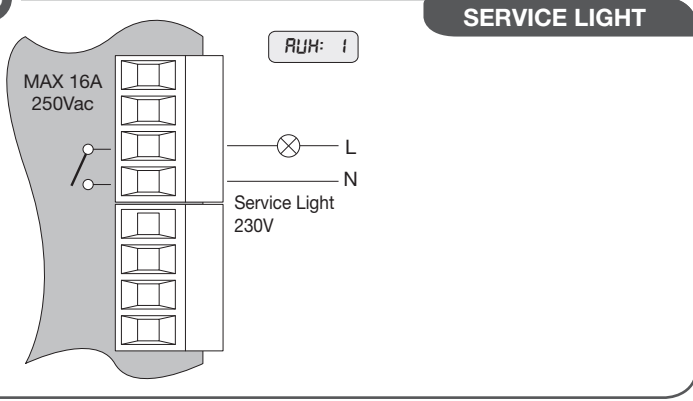

21

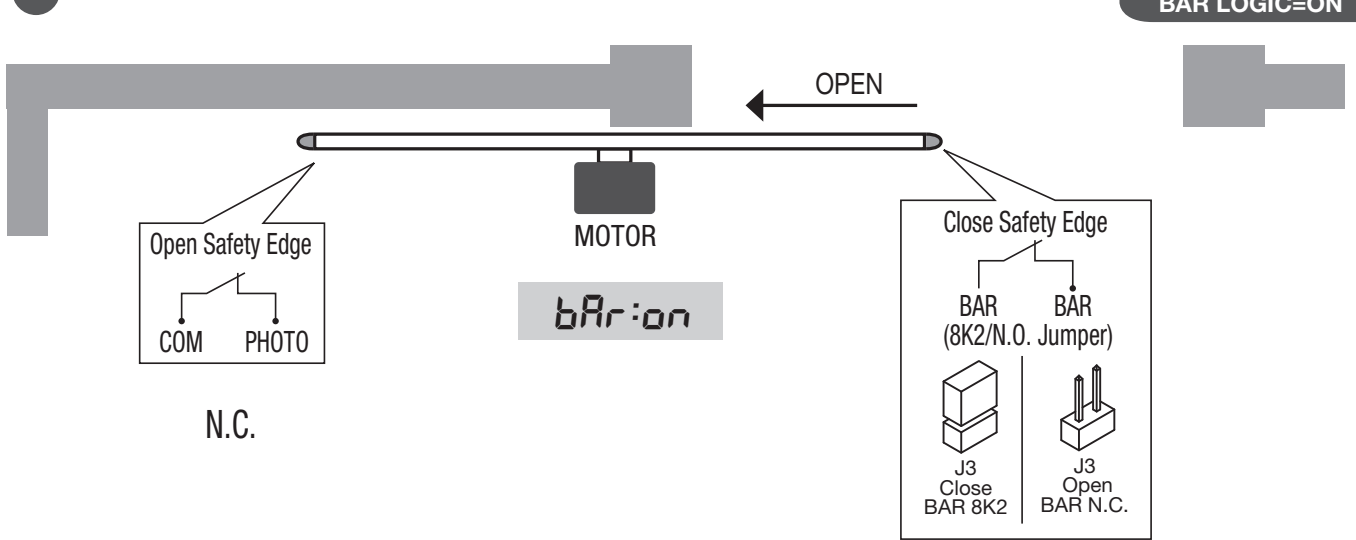

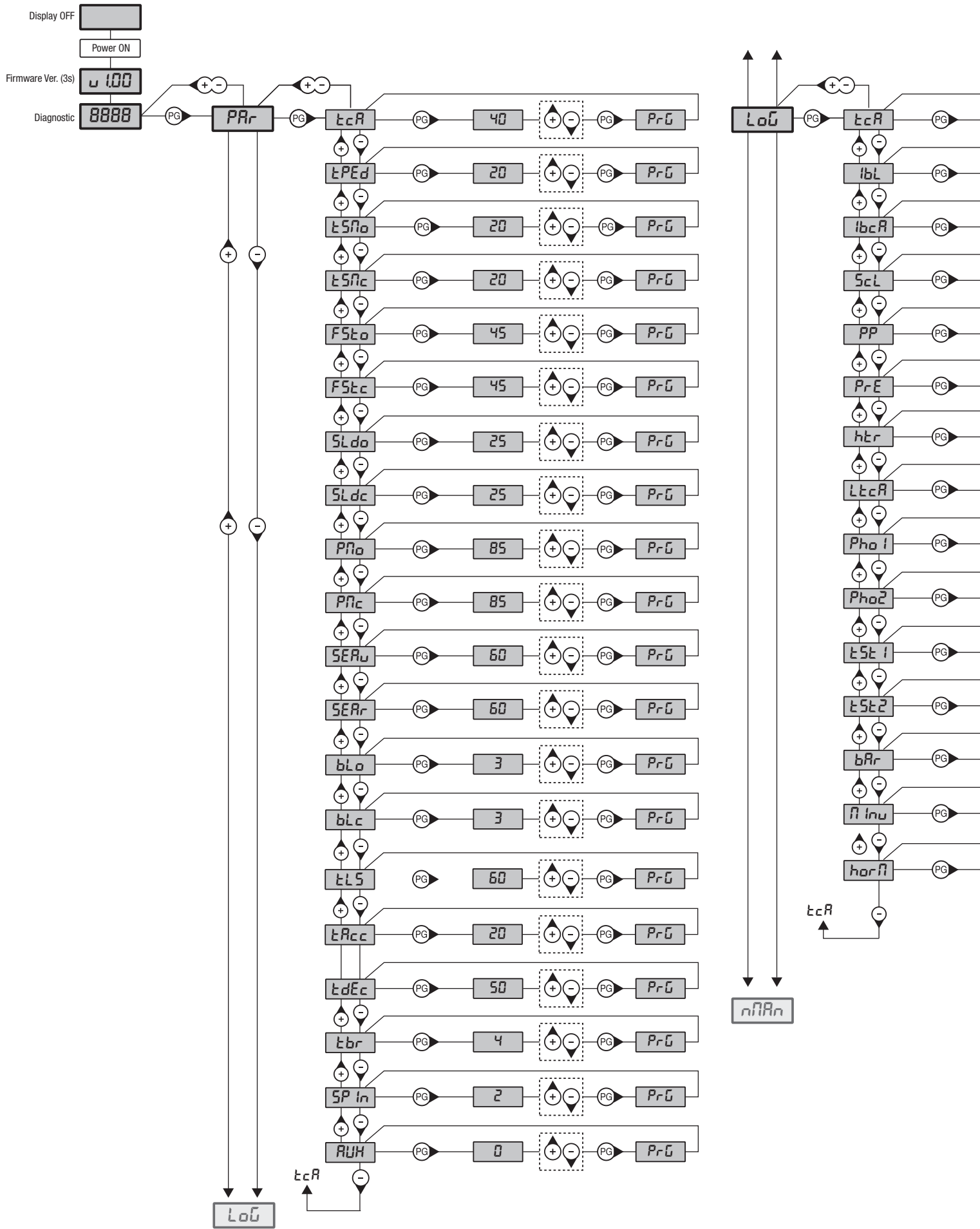

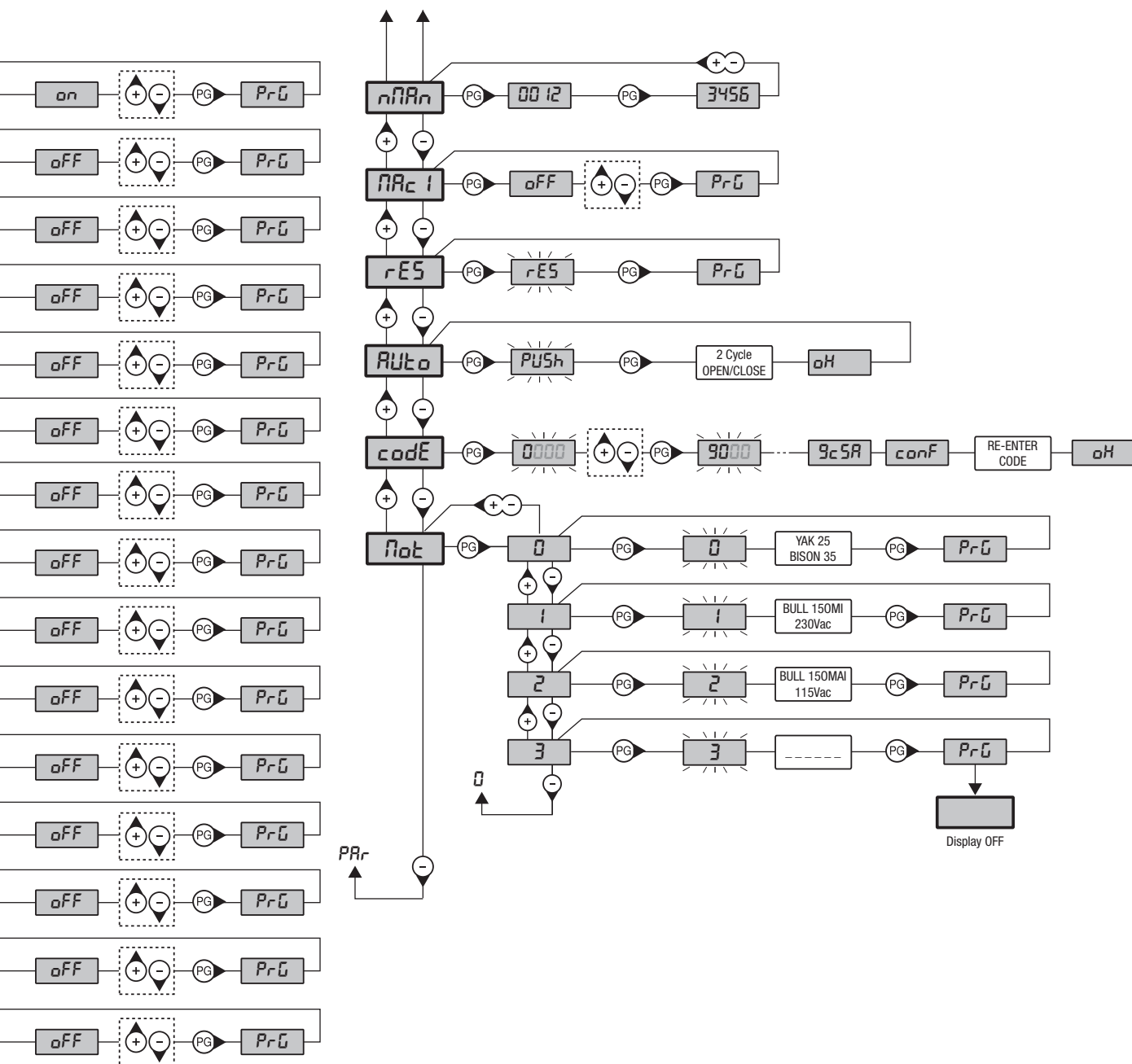

Legenda		
	Premere il tasto (-) / Press key (-) / Die Taste (-) drücken Appuyez sur la touche (-) / Presionar la tecla (-) / Wcisnąć przycisk (-)	
	Premere il tasto (+) / Press key (+) / Die Taste (+) drücken Appuyez sur la touche (+) / Presionar la tecla (+) / Wcisnąć przycisk (+)	
	Premere il tasto (PG) / Press key (PG) / Die Taste (PG) drücken Appuyez sur la touche (PG) / Presionar la tecla (PG) / Wcisnąć przycisk (PG)	
		<p>Selezionare il pulsante del trasmettitore da associare alla funzione Press the transmitter key, which is to be assigned to function Taste des Sendegeräts drücken, dem diese Funktion zugeteilt werden soll. Appuyer sur la touche du transmetteur qu'e l'on désire affecter à cette fonction. Presionar la tecla del transmisor que se desea asignar a esta función. Wcisnąć przycisk nadajnika, który zamierza się skojarzyć z tą funkcją.</p>

## INDEX

1) GENERAL FEATURES .....	21	10.2) HOW TO CHECK CONNECTIONS .....	23
2) GENERAL INFORMATION .....	21	11) PROGRAMMING .....	23
3) TECHNICAL DATA .....	21	12) TO ACCESS PROGRAMMING .....	23
4) INSTALLATION OF THE FOUNDATION PLATE .....	21	12.1) RUN SELF-LEARNING AND ANTI-CRUSHING DEVICE SETTING .....	23
5) RACK FIXING .....	22	13) PARAMETERS, LOGIC AND SPECIAL FUNCTIONS .....	24
6) LIMIT STOP FLASK POSITIONING (SEE FIG.10) .....	22	14) HOW TO ADJUST SPEED AND BRAKING .....	26
7) HOW TO INSTALL THE MAGNETS(BULL 17 OMI.S/BULL 17 OMAI.S) FIG.11	22	15) AUTOSET .....	27
8) MANUAL OPERATION (SEE FIG.12-13-14) .....	22	16) ERROR MESSAGES .....	28
9) WIRE DIAGRAM .....	22	17) DISPLAY LCD .....	28
10) CP.YAK OTI CONTROL UNIT .....	22	18) DIAGNOSTICS .....	28
10.1) INPUT/OUTPUT FUNCTIONS .....	22	19) MAINTENANCE .....	29

## QUICK PROGRAMMING

- Set the motor position by means of the menu MINV, by default the automation is set as LEFT MOTOR
  - Enter the menu AUTO, confirm 2 times with <PG> and wait until the automation has carried out the autoset of the parameters
  - By means of the menus PAR and LOG, select the parameters and the logic functions wanted according to the type of installation in object
- IMPORTANT:** After every change of the parameters FSTS, SLDO, SLDC, TSMO, TSMC, the automation executes an opening maneuver followed by a closing one in order to acquire the new values of current and torque, on the screen will appear the message <PRG>
- To store the transmitter press the receiver button plug.

## 1) GENERAL FEATURES

Automation with single-phase power supply for sliding gates

## 2) GENERAL INFORMATION

For an efficient operation of the sliding automatic mechanism, the gate must have the following features:

- The guide rail and its wheels must be suitable in size and maintained to prevent gate from excessive sliding friction.
- When running, gate must not rock excessively.
- Opening and closing stroke must be regulated by a mechanical limit stop (to safety standard in force).

## 3) TECHNICAL DATA

	BULL 17 OMI	BULL 17 OMAI
Feed	230Vac 50/60Hz	115Vac 60Hz
Absorption	7 A	8 A
Torque	68 Nm	40 Nm
Inverter	Yes	Yes
Operating jogging	40%	40%
Protection degree	IP44	IP44
Working temperature	-20°C / +50°C	-20°C / +50°C
Max. gate weight	1700 kg	1700 kg
Rack modulus	M4 Z 18*	M4 Z 18*
Opening speed	24 m/min MAX	24 m/min MAX
Noise level	<70 dB	<70 dB
Lubrication	Oil	Oil
Weight	21,3 kg	21,3 kg
* M6 Z13 (art. RI.P6 - optional)		

## 4) INSTALLATION OF THE FOUNDATION PLATE

Dimensions of the foundation plate are shown in Fig. 2.

It is essential to keep the distance from the rack, in order to position and remove the actuator once the rack is fitted to the gate leaf.

The types of fittings of the foundation plate are mainly the following:

### 1 Installation without adjustment in height on the already existing base in concrete (Fig.2).

By using the plate as drilling template, drill 4 holes Ø10mm, and insert the steel threaded screw anchors, Ø10x120mm, similar to those shown in Fig. 2. Lock the actuator directly to floor, as indicated in Fig.7.

### 2 Installation with adjustment in height on the already existing base in concrete (Fig.3).

By using the plate as drilling template, drill 4 holes, and insert the Ø 10mm steel screw anchors for threaded bars.

Tighten the 4 threaded bars, M10/120mm, and anchor the screw anchors by tightening the nuts "B" to floor with the corresponding washers.

With reference to Fig. 3, position the foundation plate by means of the adjustment nuts "A". After carrying out the required regulations, position the motor as shown in Fig.6, and lock it, as indicated in Fig.7.

### 3 Installation with adjustment in height on concrete base.

With reference to Fig. 4, fit the stretcher bolts on the foundation plate and provide for a hole of adequate size.

Immerse the stretcher bolts in concrete, then remove the nuts "D" and the 11x30, large band washers "R". Move them under the plate to allow for regulations in height of the actuator (Fig. 5).

Carry out the regulations shown in Fig. 6 and lock the motor as indicated in Fig.7.

**CAUTION: apart from the fitting modality used, carefully check that the actuator is steadily positioned and the materials are suited to the intended use.**

## 5) RACK FIXING

### Iron rack, 12x30mm M4.

Position the spacers D by welding or fit them to the gate with screws at 130/150mm height from the centre line of the slot used for fitting to the base on which the foundation plate is to be fixed.

Keep the pitch of teeth between the two parts of the rack; the joining with another piece of rack would make it easier to achieve (see Fig.8)

Secure the rack with the screws V making sure, once the actuator has been installed, that between rack and the drive gear there is always approx. 1mm clearance (see Fig.9); to get this clearance use the slots on the rack.

## 6) LIMIT STOP FLASK POSITIONING (SEE FIG.10)

Open manually the gate and leave approximately of 1÷3cm, depending on gate weight, between gate and positive mechanical stop A; tighten the limit stop flask S with the grains G to press the limit stop micro. Repeat the sequence with closing gate.

## 7) HOW TO INSTALL THE MAGNETS(BULL 17 OMI.S/BULL 17 OMAI.S) FIG.11

The magnets are housed in special supports (fig.11-"A"). These magnets are to be fitted to the limit switch brackets or the rack and cause the triggering of sensors when they approach them.

Fitting onto the limit switch brackets

The bases are complete with hooking tongue allowing the fitting of the magnets to the limit switch bracket supplied with the operator, as shown in Fig.11-B. This type of fitting allows to rapidly adjust the position of magnets. After calculating the correct distance, fix the support in the correct position by means of a screw, so as to avert the moving of the bracket.

Fitting onto the rack

As an alternative, the supports can be fitted directly to the rack, by using the slots shown in Fig. 11-C. This fitting mode does not allow for subsequent regulations. It is therefore advised to make some trials with temporarily fitted supports before carrying out the final fitting.

**IMPORTANT:** The correct distance of the magnet with respect to the sensor depends on the installation characteristics. This space cannot be preset and must be adjusted on a trial basis.

The distances regarding the triggering of the sensor (value X) with respect to distance K of 3 and 35 mm, which are shown in Fig. 11 are only indicative. In any case, distance K must not exceed 35 mm as a higher distance will not allow the triggering of the magnetic sensor.

## 8) MANUAL OPERATION (SEE FIG.12-13-14)

In the event of power failure or malfunction, to manually operate the gate proceed as follows:

- After inserting the customized key C, turn it anti-clockwise and pull the lever L.
- The geared motor is unlocked and the gate can be moved by hand.
- To return to the normal operating mode, close the lever L again and manually activate the gate until it is geared.
- Move the gate in one of the limit switches so that the next maneuver is at normal speed.

## 9) WIRE DIAGRAM

For the wire connections of the system and to adjust the operating modes, please refer to the Instruction Manual of the control unit.

**In particular, the anti-crash device (encoder) should be adjusted according to regulations in force.**

Please remember that the device **should be earthed** by means of the appropriate terminal.

## 10) CP.YAK OTI CONTROL UNIT

### 10.1) INPUT/OUTPUT FUNCTIONS

Terminals	Function	Description
L-N-GND	Power supply	Power input of single-phase network. L: Phase - N: Neutral - GND: Engine housing earth connection. Please note that the ground must be connected as indicated in the diagram in Fig. 11.
U-V-W	Three-phase engine	U-V-W three-phase engine connection.
Lamp	Flashing	Flashing connection 230Vac 40W max or 115Vac 40W max (BULL 17 OMAI).
24 Vdc	24 Vdc	Power supply output accessories 24Vdc/500mA max.
SCA	SCA	Voltage free N.O. contact for open gate light 24 Vac, 0.5 A max, configurable via the SCA logic
Phototest	Phototest	Phototest output for verified photocells, see figure 17
COM	Common	Common for all control inputs.
OPEN	Opens	OPEN button input (N.O. contact).
CLOSE	Closes	CLOSE button input (N.O. contact).
P.P.	Step-step	Step-step button input (N.O. contact)
PED	Pedestrian	Pedestrian button input (N.O. contact)
STOP	Stop	STOP button input (N.C. contact)
PHOTO	Opening photocell	Input for photocell active only in the opening phase
PHOTC	Closing photocell	Input for photocell active only in the closing phase

COM	Common	Common for limit switch.
SWC	Closing Limit Switch	CLOSING limit switch input (N.C. contact)
SWO	Opening Limit Switch	OPENING limit switch input (N.C. contact)
BAR	Sensing safety edge	Sensing edge contact input Resistive safety edge (8K2): JP1 "BAR" closed Mechanical safety edge (N.C.): JP1 "BAR" open The intervention of the safety edge stops the movement of the gate and reverses for approximately 3s. Note: this entry is connected the safety transformer mounted on the hand release lever that prevents any maneuver if the motor released. The sensitive edge must be connected in series to this Microswitch, as shown in Figure 21
RADIO	Radio receiver	Quick connector for plug radio receiver.
2CH	Second channel	N.O. output of the second radio channel of the radio receiver. (max 24Vac/dc 1A)
BRAKE	Brake Resistance	Input for braking current dissipation resistance The resistance is only used on 230V BULL 17 OMI
P3		Not used
CON1		Not used
J7		Not used
J8		Not used
SW1	Dip1, Dip2	Keep it ON
U1	CONFIGURATION MEMORY	E-Eprom extractable memory. it contains all the configurations of the unit (logical, parameters, etc.), excluding radio transmitters. In case of failure it is possible to extract the E-Eprom and insert it in a different unit, thus avoiding reprogramming.

## 10.2) HOW TO CHECK CONNECTIONS

- 1) Cut off power supply.
- 2) Manually release the door/gate and push it for about half stroke. Lock the door again.
- 3) Restore power supply.
- 4) Send a step-by-step command through push-button <-> on the control unit (LCD display off). To stop the door/gate press <-> once more.
- 5) The door/gate should open. If not, set the MINV logics to change the opening direction (default MINV=OFF) Engine installed to the left.

## 11) PROGRAMMING

The programming of the various functions of the control unit is carried out using the LCD display on the control unit and setting the desired values in the programming menus described below.

The parameters menu allows you to assign a numerical value to a function, in the same way as a regulating trimmer.

The logic menu allows you to activate or deactivate a function, in the same way as setting a dip-switch.

Other special functions follow the parameters and logic menus and may vary depending on the type of control unit or the software release.

## 12) TO ACCESS PROGRAMMING

- 1 - Press the button <PG>, the display goes to the first menu, Parameters "PAR".
- 2 - With the <+> or <-> button, select the menu you want.
- 3 - Press the button <PG>, the display shows the first function available on the menu.
- 4 - With the <+> or <-> button, select the function you want.
- 5 - Press the button <PG>, the display shows the value currently set for the function selected.
- 6 - With the <+> or <-> button, select the value you intend to assign to the function.
- 7 - Press the button <PG>, the display shows the signal "PRG" which indicates that programming has been completed.

### 12.1) RUN SELF-LEARNING AND ANTI-CRUSHING DEVICE SETTING

When operator assembly and wiring is completed, parameters and logic are programmed, self learning allows the operator to learn the stroke and torque. Enter menu Auto and press the button < PG >, PUSH will be displayed.

Press again the button < PG >: self-learning is beginning: PRG will be displayed, and the control panel completes some opening/closing cycles.

When the procedure is completed OK will be displayed.

This procedure can be followed from any position of the gate/door leaf and can be stopped at any moment by pressing keys <+> and <-> at the same time, or through the activation of STOP/PHO/PHA/BAR/PP/PED inputs.

If the procedure is not successful, the wording ERR appears. Check that no obstacles or frictions are present.

After the AUTOSSET procedure it is necessary to check the value of the operating forces according to the European Standards EN12445 and EN12453. If the value of the force is too high it is mandatory to install a safety edge which complies to the standard EN12978.

Check the value of the operative forces in accordance with EN12445 and EN12453 at the end of the autoset phase. If the value of the force is too high install an edge compliant with EN12978.

#### Notes:

Pressing <-> with the display turned off means an impulse of P.P.

Simultaneously pressing <+> and <-> from inside a function menu allows you to return to the previous menu without making any changes.

Hold down the <+> key or the <-> key to accelerate the increase/decrease of the values.

After waiting 30s the control unit quits programming mode and switches off the display.

### 13) PARAMETERS, LOGIC AND SPECIAL FUNCTIONS

The tables below describe the individual functions available in the control unit.

PARAMETERS (PAr)			
MENU	FUNCTION	MIN-MAX-(Default)	MEMO
t <sub>cA</sub>	Automatic closure time. It is activated only with "TCA" logics :ON At the end of the preset time, the control unit starts a new closing operation.	1-240-(40s)	
t <sub>PEd</sub>	The passage left open by the door/gate leaf during the partial opening controlled by the pedestrian inoput, is adjusted. The value is expressed in percentage on the aggregate value of the stroke.	5-100-(20%)	
t <sub>SN<sub>o</sub></sub>	It adjusts the duration of the OPENING slowdown phase. The value is expressed as a percentage of the total value of the stroke. See section "How to adjust speed and braking".	10-100-(20%)	
t <sub>SN<sub>c</sub></sub>	It adjusts the duration of the CLOSING slowdown phase. The value is expressed as a percentage of the total value of the stroke. See section "How to adjust speed and braking".	10-100-(20%)	
F <sub>St<sub>o</sub></sub>	The opening and closing speed is adjusted. <b>IMPORTANT: Change the values of this parameter only by keeping to the weight limits shown in Table 1.</b> See section "How to adjust speed and braking".	20-120-(45)	
F <sub>St<sub>c</sub></sub>	The opening and closing speed is adjusted. <b>IMPORTANT: Change the values of this parameter only by keeping to the weight limits shown in Table 1.</b> See section "How to adjust speed and braking".	20-120-(45)	
S <sub>L<sub>do</sub></sub>	Speed during braking is adjusted. See section "How to adjust speed and braking".	10-40-(25)	
S <sub>L<sub>dc</sub></sub>	Speed during braking is adjusted. See section "How to adjust speed and braking".	10-40-(25)	
P <sub>N<sub>o</sub></sub>	The torque applied to motor 2 in the opening* phase is adjusted.	1-99-(85%)	
P <sub>N<sub>c</sub></sub>	The torque applied to motor 2 in the closing* phase is adjusted.	1-99-(85%)	
S <sub>EA<sub>o</sub></sub>	The trigger time of the anti-crash device (Encoder) is adjusted during the normal speed phase*. 0:Off-99: maximum sensibility - 1: minimum sensitivity	Ø-90-(60%)	
S <sub>EA<sub>r</sub></sub>	The trigger time of the anti-crash device (Encoder) is adjusted during the braking phase*. 0:Off-99: maximum sensibility - 1: minimum sensitivity	Ø-90-(60%)	
b <sub>L<sub>o</sub></sub>	Stop space is adjusted after reaching the opening and closing limit switch. This value is expressed in centimetres. See section "How to adjust speed and braking".	1-10-(3)	
b <sub>L<sub>c</sub></sub>	Stop space is adjusted after reaching the opening and closing limit switch. This value is expressed in centimetres. See section "How to adjust speed and braking".	1-10-(3)	
t <sub>LS</sub>	It is activated with AUX parameter only, preset to value 1. The activation time of the service light is adjusted.	1-240-(60s)	
t <sub>Acc</sub>	Ramp during acceleration. Value expressed in tenths of seconds. See section "How to adjust speed and braking".	1-25-(20)	
t <sub>dEc</sub>	Ramp during deceleration.	50-99-(50)	
t <sub>br</sub>	Emergency braking, after the activation of PHOT/BAR/STOP inputs, the value is expressed in tenths of seconds (for adjustment see table 1).	1-20-(7)	
S <sub>P<sub>in</sub></sub>	It adjusts the reversal distance that the gate travels following the intervention of the sensing edge (SAFETY EDGE). During the reversal phase, further interventions of the sensing edge are ignored, the intervention of the sensing edge causes stopping. If during reversal (in the OPEN and CLOSE direction) a related photocell (PHOTO or PHOTC) is active, the parameter is ignored and the reversal space must be minimal (10 cm). The minimum value 1 equals approximately 20 cm, the maximum value 4 equals approximately 60 cm.	1-4-(1)	
A <sub>UH</sub>	It selects the operating mode of the SCA output: 0: SCA 1: Service light. The contact closes for the time preset with TLS parameter. The countdown starts at the inception of the opening operation. 2: Area light. The contact closes in the opening phase and remains closed for the entire TCA time. It opens only with closed door. See wiring shown in figure 17.	Ø-2-(Ø)	

LOGIC (L05)			
MENU	FUNCTION	ON-OFF-(Default)	MEMO
<i>t c A</i>	Enables or disables automatic closing On: automatic closing enabled Off: automatic closing disabled	(ON)	
<i>l b L</i>	Enables or disables multi-flat function. On: multi-flat function enabled. The step-by-step and pedestrian commands have no effect during the opening phase. Off: multi-flat function disabled.	(OFF)	
<i>l b c A</i>	During the TCA phase, the PP controls are enabled or disabled. On: PP controls are disabled. Off: PP controls are enabled.	(OFF)	
<i>S c L</i>	The rapid closure is enabled or disabled. It can be activated only if TCA:ON On: enabled rapid closure. With open gate, the photocell activation causes the automatic closure after 3 s. If the photocell is activated during the opening phase, the operation is completed and closure starts after 3s Off: disabled rapid closure.	(OFF)	
<i>PP</i>	The operating mode of "P.P. Push button" and of the transmitter are selected. On: Operation : OPEN > CLOSE > OPEN > Off: Operation: OPEN > STOP > CLOSE > STOP >	(OFF)	
<i>P r E</i>	Forewarning flashing light enabled or disabled. On: enabled forewarning flashing light. The flashing light is activated 3 s before the starting of the motor. Off: disabled forewarning flashing light.	(OFF)	
<i>h t r</i>	The Service Man function is enabled or disabled. On: Service Man operation. The OPEN/CLOSE push buttons should be kept pressed for the entire operating time. Off: Automatic operation.	(OFF)	
<i>L t c A</i>	During the TCA time, the blinker is enabled or disabled. On: Enables blinker. Off: Disables blinker.	(OFF)	
<i>Pho 1</i>	The PHOT O input is enabled or disabled in the opening phase. On: Photocell 1 activated only in the closing phase. Off: Photocell 1 activated in both opening and closing phases.	(OFF)	
<i>Pho 2</i>	The PHOT C input is enabled or disabled in the opening phase. On: Photocell 1 activated only in the closing phase. Off: Photocell 1 activated in both opening and closing phases.	(OFF)	
<i>t S t 1</i>	The check on the photocell connected to PHOTO input is activated or deactivated Before operation, the control unit checks the switching of the photocell contact. The test shall be carried out following any command (PP, OPEN, CLOSE, radio, TCA) with engine off before performing the manoeuvre (even partial manoeuvres). The test is not carried out when the engine already in motion must stop and then reverse following the SAFETY EDGE or PHOT intervention. If the checks are not successful, the door/gate will not move. On: activated check on photocell. Off: deactivated check on photocell.	(OFF)	
<i>t S t 2</i>	As for TST1, but referred to PHOTC input	(OFF)	
<i>b A r</i>	It changes the mode of operation of the PHOTO inputs (photocell in OPEN) and BAR in case the sensitive safety edges are installed in the mobile opening and closing edges. On: The PHOTO input takes on a similar function to the BAR input but inverts the motion for the distance set with the SPIN parameter if the sensing edge to which it is connected is pressed during the opening phase (if the photocells in CLOSE are busy, it reverses for 10 cm). The safety edge connected to the BAR input is only active during the CLOSING phase. Off: The intervention of the sensing safety edge connected to the BAR input stops the movement of the gate and inverts the motion for the distance set with the SPIN parameter (if the photocell in the inversion direction is busy it reverses for 10cm) , both in OPENING and CLOSING. The PHOT OPEN input resumes the operation of the photocell active in opening.	(OFF)	
<i>n l n u</i>	The opening direction of the motor is selected (see Fig. 4): On: Right side motor mount Off: Left side motor mount	(OFF)	
<i>h o r n</i>	Enable or disable the transition from Automatic to Man Present mode. The logic is associated with the state of the PED input. On: If at least one of the inputs: DAS, PHOTO or PHOTC remains active (open contact) for at least 10 seconds, regardless of the position of the door, the unit switches to Man Present mode (only the OPEN/ CLOSE/ SWO/ SWC inputs are active), after activating the PED command. For further safety purposes, it is necessary that during the OPEN/CLOSE command, the PED input is closed. Use an N.O. key for this function, with automatic release. Off: Automatic switch disabled. The logic also works with PHOTOTEST enabled. (OFF)	(OFF)	

## NUMBER OF CYCLES (n<sub>PRn</sub>)

The number of cycles (open+close) completed by the system is displayed.  
When the push-button <PG> is pressed once, the first 4 digits are displayed, if the push-button is pressed once more, the last 4 digits are displayed.  
E.g. <PG> 0012 >>> <PG> 3456: 123.456 cycles were performed.

## MAINTENANCE (n<sub>RC i</sub>)

This function allows to activate the indication of maintenance required after a certain number of operations, preset by the installer.  
To activate and select the number of operations, proceed as follows:  
Press the <PG> button, OFF is displayed, indicating that the function is disabled (default).  
Select one of the numbers shown (from OFF to 100) by using the <+> and <-> keys . The figures express the value of hundreds of cycles (e.g.: the number 50 means 5000 operations).  
Press OK to activate the function. The PROG message is displayed.  
When the flashing light flashes for around 10 sec at end of operation, this means that maintenance operations are needed.

## RESET (r<sub>ES</sub>)

RESET of the control unit. WARNING: Returns the control unit to the default values.  
When the <PG> push-button is pressed once, the RES wording begins to flash, if the push-button <PG> is pressed once more, the control unit is reset.  
Note: neither the transmitter codes nor the position and stroked of the gate leaf will be erased from the receiver.

## AUTOSET (A<sub>U</sub>t<sub>o</sub>)

The automatic system stroke is self learned. See section "STROKE SELF-LEARNING"

## PASSWORD (c<sub>od</sub>E)

It allows to type in an access protection code to the programming of the control unit.  
A four-character alphanumeric code can be typed in by using the numbers from 0 to 9 and the letters A-B-C-D-E-F.  
The default value is 0000 (four zeros) and shows the absence of a protection code.  
While typing in the code, this operation can be cancelled at any moment by pressing keys + and - simultaneously. Once the password is typed in, it is possible to act on the control unit by entering and exiting the programming mode for around 10 minutes in order to allow adjustments and tests on functions.  
By replacing the 0000 code with any other code, the protection of the control unit is enabled, thus preventing the access to any other menu. If a protection code is to be typed in, proceed as follows:  
- select the Code menu and press OK.  
- the code 0000 is shown, also in the case a protection code has been previously typed in.  
- the value of the flashing character can be changed with keys + and -.  
- press OK to confirm the flashing character, then confirm the following one.  
- after typing in the 4 characters, a confirmation message "CONF" appears.  
- after a few seconds, the code 0000 appears again  
- the previously stored protection code must be reconfirmed in order to avoid any accidental typing in.  
If the code corresponds to the previous one, a confirmation message "OK" appears.  
The control unit automatically exits the programming phase. To gain access to the Menus again, the stored protection code must be typed in.  
**IMPORTANT: TAKE NOTE of the protection code and KEEP IT IN A SAFE PLACE for future maintenance operations. To remove the code from a protected control unit, enter the programming mode with the password and reset the code to the 0000 default value.**  
**IF YOU LOOSE THE CODE, PLEASE CONTACT THE AUTHORISED SERVICE CENTER FOR THE TOTAL RESET OF THE CONTROL UNIT.**

## ENGINE TYPE SELECTION (m<sub>o</sub>t)

It allows for selecting the configuration of the unit for the type of engine used.  
Normally the correct value is factory preset and does not need any intervention on the part of the installer.  
Only in case of replacement of the unit, it is necessary to set the correct value, each digit corresponding to a given engine model, as per the list below.

- 0: YAK25/BISON35
- 1: BULL 17 OMI 230Vac
- 2: BULL 17 OMAI 115Vac
- 3: NOT USED

The display always shows the abbreviation MOT followed by the engine number currently set (example MOT.1,MOT.2).

## 14) HOW TO ADJUST SPEED AND BRAKING

The door/gate stroke is shown in the following scheme:

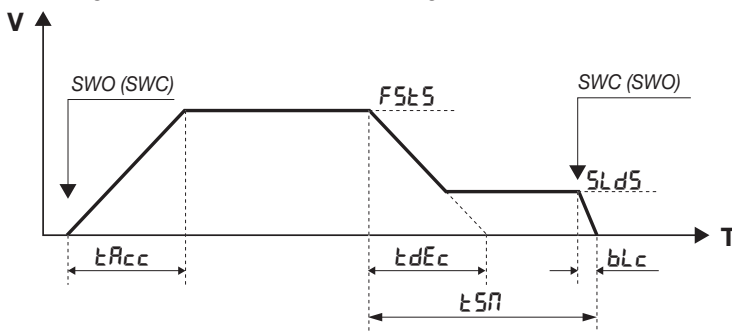

The V axis is the gate/door speed, T axis is the time required by the door/gate to move from a limit switch to the other. The parameters govern both the opening and the closing phases.

At gate/door stopped on any SWO (SWC) limit switch, when a control key is pressed the gate/good starts moving and reaches the standard operating speed, which can be adjusted by FST<sub>S</sub>/FST<sub>C</sub> parameter.

The TACC time sets how rapidly the gate/door should reach the standard speed.

Before meeting the SWX (SWO) stop limit switch, braking preset by TSM time will start.

Braking leads the gate/door from standard speed (FSTSO/FSTSC) to braking speed, adjusted by SLDS parameter.

The TDEC time sets how rapidly the gate/door should reach the braking speed.

The TDEC time is theoretical by reason of the fact that as soon as the speed reaches the value preset by SLDS, braking at constant speed starts until reaching the SWC (SWO) limit switch.

Once the limit switch is reached, the gate/door continues its movement for a period of time adjusted by BLC parameter, until entire stop.

The following diagram graphically represents the stroke of the gate in case of intervention of a safety input (STOP/PHOT/BAR):

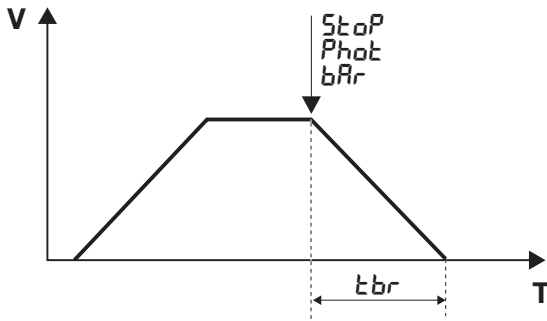

The intervention of the safety input causes an immediate slowing of the gate, the time in which the gate switches from standard speed to a complete stop is adjustable through the TBR value and must respect the values indicated in Table 1.

**IMPORTANT:**

- For the correct operation of parameters it is mandatory that the AUTOSET be carried out correctly (see STROKE LEARNING).
- If the FSTo(FSTc) speed is increased, TSMo(TSMc), TACC and TDEC values must be increased proportionally in order to avert any mechanical stress to the gear motor.
- The TBR value must be set according to those indicated in table 1, setting a TBR that is too short on a gate with strong inertia may damage the automation. A TSMo (TSMc) value, which is too short, combined with a TDEC value, which is too high, might result in the cancellation of the SLDo (SLDc) braking phase due to the gate leaf friction and the triggering of the limit switches when the speed is still high. This situation must be absolutely avoided.
- The AUTO function does not change the default values of the above-mentioned parameters. The latter must be preset by the installer according to the gate/door specifications.
- An NC contact that opens whenever the engine is unlocked or the casing is removed will also be serially wired in the BAR input with the SAFETY EDGE (or the SAFETY EDGES). Thus, in situation 1. unit powered, 2. Engine stopped, 3. SWO and SWC not engaged (i.e. engine out of limit switches), if the BAR input is activated and then reactivated (engine locked and carter inserted, ready to restart), upon the subsequent PP/OPEN/CLOSE command (also by radio) it is necessary to force a slow manoeuvre.

TABLE 1	BULL 17 OMI / BULL 17 OMAI			
WEIGHT Kg	FSTO/FSTC Max	TBR Min	TSMO/TSMC Min	V m/1'
1700	85	2	30	17
1000	100	3	35	20
500	120	4	50	24

Depending on the actuator model and the weight of the gate, set the speed value in opening and closing (FSTO/FSTC), the minimum value of the TBR braking and the minimum value of the TSMO/TSMC slowdown distance.

At each combination we obtain the value of the speed of the gate (Column V) expressed in meters/minute.

Exceeding the recommended values may cause damage and malfunction, the manufacturer does not assume any responsibility arising from improper FSTO/FSTC/TBR/TSMO/TSMC value settings.

The values reported are indicative and referred to a standard installation, the installer must nevertheless ensure compliance with the limits set by the EN 12453, EN 12445 standards.

**15) AUTOSET**

For a correct operation of braking it is essential that the stroke is memorised. This can be performed either using the above described AUTO function or when the first operation is completed (then carried out without interruptions) from SWO to SWC (or viceversa).

The engine starts in SLOW mode to search for SWO, it stops, then reverses still in SLOW manoeuvre to search for SWC (determining the stroke). Then first FAST manoeuvre from SWC to SWO (ramps, speed, slowdowns determined by the TSMo/TSMc/FSTo/FSTc/SLDo/SLDc parameters set) and second fast manoeuvre from SWO to SWC.

However, these values can be manually modified at a second time.

If you manually change a parameter that requires a new acquisition, the unit will perform a complete opening and closing manoeuvre, the message "PRG" will be displayed. At the end the operation will return to normal.

It is not possible to carry out the autosest with logic HTR:ON

## 16) ERROR MESSAGES

Some messages that are displayed in the event of malfunctions are shown hereunder:

<i>Err</i>	Error N.O inputs (autoset)	If the error occurs during self-learning, check the PP/PED/OPEN/CLOSE inputs.
<i>Err 1</i>	STOP error (autoset)	STOP intervention during the autoset.
<i>Err 2</i>	Error, photocells (Autotest)	PHOTO/PHOTC intervention during the autoset.
<i>Err 4</i>	Error, sensitive edge (autoset)	BAR intervention during autoset.
<i>Err 5</i>	Error, phototest	Check the operation and correct connection of the photocells.
<i>RNP</i>	Triggering of the amperometric sensor	An obstacle or a point of friction has caused the triggering of the amperometric sensor. Remove the obstacle or check the door stroke.
<i>F01</i>		The brake connected absorbs too much.
<i>F02</i>		Short circuit on the engine. Check the impedance of the windings and the insulation between each phase of the motor and the ground.
<i>F04</i>		At power-on the bus voltage is not within the specifications. Check the supply voltage, or the correct selection of the engine according to the menu Mot.
<i>F05</i>		Over temperature detected in the unit.
<i>F06</i>		Instantaneous current threshold exceeded. Unlock the engine and check that the pinion is free to turn. If necessary, contact technical assistance.
<i>F07</i>		Instantaneous current threshold exceeded. Unlock the engine and verify that there are no excessive loads (difficulty moving) along the entire travel of the gate. If necessary, contact technical assistance.
<i>F08</i>		Exceeded maximum allowed voltage on the power bus. Check the supply voltage. Carry out the following actions in the order indicated: 1. Increase TDEC and TSMO/TSMC parameters, check intermediate stops with STOP/PP/PHOT/BAR commands, if the problem recurs, go to the following point: 2. Increase parameter TBR, check intermediate stops with STOP/PP/PHOT/BAR commands, if the problem recurs go to the following point: 3. Connect braking resistance, check intermediate stops with STOP/PP/PHOT/BAR commands, if the problem recurs go to the following point: 4. Decrease the parameters FSTO/FSTC, check intermediate stops with STOP/PP/PHOT/BAR commands.
<i>F09</i>		The values set are incorrect and the gate goes past the limit switch. Act by modifying the following parameters in order: - <i>bLc</i> / <i>bLc</i> (decrease) - <i>t5na</i> / <i>t5nc</i> (increase) - <i>SLda</i> / <i>SLdc</i> (decrease) - <i>F5ta</i> / <i>F5tc</i> (decrease)

## 17) DISPLAY LCD

The LCD display can be turned by 180°.

- Cut off mains power supply
  - Press PGM
  - While keeping PGM pressed, reset the mains power supply
  - Keep PGM pressed (around 5 sec) until the software version appears, turned by 180°.
- Normally proceed with programming.

## 18) DIAGNOSTICS

In the event of operating anomalies the status of all inputs (stop command and safety) can be displayed. One segment of the display is linked to each input. In the event of failure it switches on according to the following scheme.

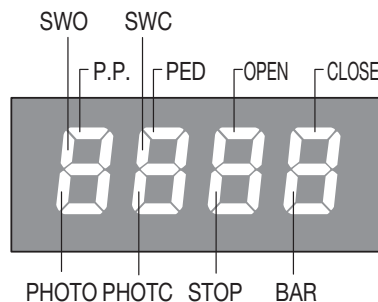

LD1 LED: Mains power present.

LD2 LED: PRESENT + 5V

PHOTO: PHOT1/TST1

PHOTC: PHOT2/TST2

F4: Power supply line protection fuse 15AT.

## 19) MAINTENANCE

The following table is used to record maintenance operations, improvement or repair works carried out by the expert engineer.

Date _____	Engineer's Signature _____	Stamp
Description of operation ----- -----		
Date _____	Engineer's Signature _____	Stamp
Description of operation ----- -----		
Date _____	Engineer's Signature _____	Stamp
Description of operation ----- -----		
Date _____	Engineer's Signature _____	Stamp
Description of operation ----- -----		
Date _____	Engineer's Signature _____	Stamp
Description of operation ----- -----		
Date _____	Engineer's Signature _____	Stamp
Description of operation ----- -----		
Date _____	Engineer's Signature _____	Stamp
Description of operation ----- -----		
Date _____	Engineer's Signature _____	Stamp
Description of operation ----- -----		
Date _____	Engineer's Signature _____	Stamp
Description of operation ----- -----		
Date _____	Engineer's Signature _____	Stamp
Description of operation ----- -----		
Date _____	Engineer's Signature _____	Stamp
Description of operation ----- -----		

## User's handbook

### Safety measures

- Do not stand within the gate movement area.
- Children must not play with controls and near the gate.
- In the event of malfunctions, do not attempt to repair the failure but contact the specialised personnel.

### Manual and emergency manoeuvre

In the event of power failure or malfunction, to manually operate the gate proceed as follows:

- After inserting the customized key C, turn it anti-clockwise and pull the lever L.
- The geared motor is unlocked and the gate can be moved by hand.
- To return to the normal operating mode, close the lever L again and manually activate the gate until it is geared.

### Maintenance

- Every month check the good operation of the emergency manual release.
- It is mandatory not to carry out extraordinary maintenance or repairs as accidents may be caused. These operations must be carried out by qualified personnel only.
- The operator is maintenance free but it is necessary to check periodically if the safety devices and the other components of the automation system work properly. Wear and tear of some components could cause dangers.

### Waste disposal

If the product must be dismantled, it must be disposed according to regulations in force regarding the differentiated waste disposal and the recycling of components (metals, plastics, electric cables, etc.). For this operation it is advisable to call your installer or a specialised company.

### Warning

All Benincá products are covered by insurance policy for any possible damages to objects and persons caused by construction faults under condition that the entire system be marked CE and only Benincá parts be used.

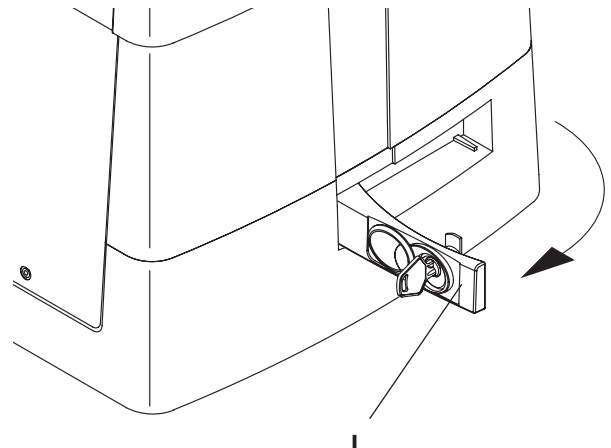
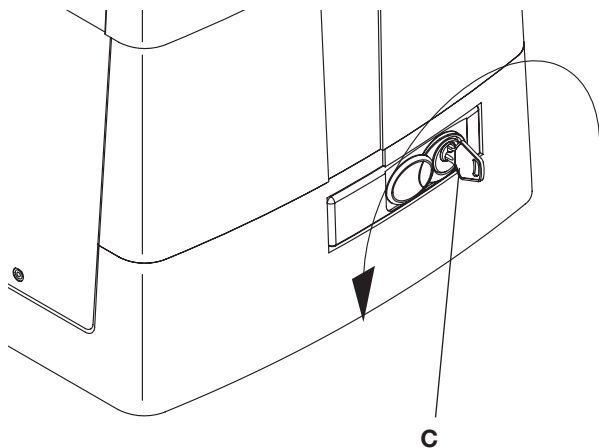

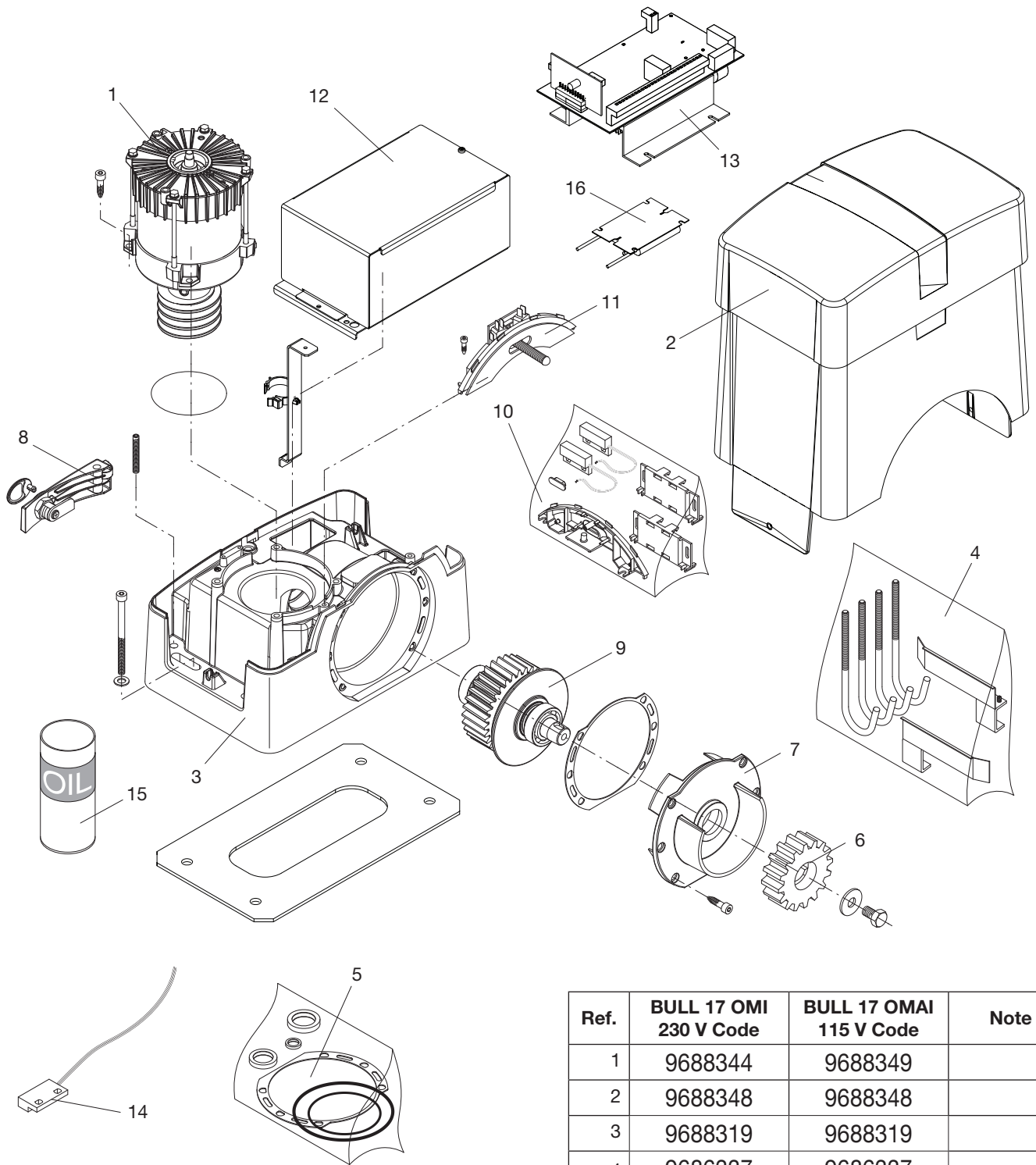

Ref.	BULL 17 OMI 230 V Code	BULL 17 OMAI 115 V Code	Note
1	9688344	9688349	
2	9688348	9688348	
3	9688319	9688319	
4	9686337	9686337	
5	9686694	9686694	
6	9686032	9686032	
7	9686335	9686335	
8	9688317	9688317	
9	9688270	9688270	
10	9688102	9688102	BULL_S
11	9686329	9686329	
12	9688335	9688335	
13	9688336	9688336	
14	9688318	9688318	
15	9686094	9686094	
16	9688350	--	

## Dichiarazione di Conformità UE (DoC)

Nome del produttore: **Automatismi Benincà SpA**  
Indirizzo: **Via Capitello, 45 - 36066 Sandrigo (VI) - Italia**  
Telefono: **+39 0444 751030** Indirizzo e-mail: **sales@beninca.it**  
Persona autorizzata a costruire la documentazione tecnica:  
**Automatismi Benincà SpA**

*Dichiara che il documento è rilasciato sotto la propria responsabilità e appartiene al seguente prodotto:*

Tipo di prodotto: **Attuatore elettromeccanico per cancelli scorrevoli**  
Modello/Tipo: **BULL 17 OMI** Accessori: **N/A**

*Il prodotto sopraindicato risulta conforme alle disposizioni imposte dalle seguenti direttive:*

**Direttiva 2014/53/EU**  
**Direttiva 2011/65/EU**  
**Direttiva 2006/42/CE**

*Sono state applicate le norme armonizzate e le specifiche tecniche descritte di seguito:*

ETSI EN 300 220-1 V3.1.1  
ETSI EN 300 220-2 V3.1.1  
ETSI EN 301 489-1 V2.1.1  
ETSI EN 301 489-3 V2.1.1  
EN 50950-1:2006 + A11:2009 + A1:2010 + A12:2011 + AC:2011 + A2:2013  
EN 61000-6-2:2005, EN 61000-6-3:2007 + A1:2011  
EN 60335-1:2012 + A11:2014; EN 60335-2-103:2015  
50581-2012  
EN 13241-1:2003  
EN 12445:2002, EN 12453:2002, EN 12978:2003 (se applicabile).

*Il Certificato di Conformità di questo documento corrisponde all'ultima revisione disponibile al momento della stampa e può risultare differente per esigenze editoriali dall'originale disponibile presso il produttore.*

Benincà Luigi, Responsabile legale.  
Sandrigo, 18/04/2018.

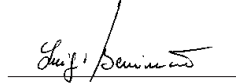

## UE Declaration of Conformity (DoC)

Manufacturer's name: **Automatismi Benincà SpA**  
Address: **Via Capitello, 45 - 36066 Sandrigo (VI) - Italia**  
Telephone: **+39 0444 751030** Email address: **sales@beninca.it**  
Person authorised to draft the technical documentation:  
**Automatismi Benincà SpA**

*Declare that the DOC is issued under our sole responsibility and belongs to the following product:*

Product type: **Electromechanical motor for sliding gates**  
Model/type: **BULL 17 OMI** Accessories: **N/A**

*The object of the declaration described above is in conformity with the relevant Union harmonization legislation:*

**Directive 2014/53/EU**  
**Directive 2011/65/EU**  
**Directive 2006/42/CE**

*The following harmonized standards and technical specifications have been applied:*

ETSI EN 300 220-1 V3.1.1  
ETSI EN 300 220-2 V3.1.1  
ETSI EN 301 489-1 V2.1.1  
ETSI EN 301 489-3 V2.1.1  
EN 50950-1:2006 + A11:2009 + A1:2010 + A12:2011 + AC:2011 + A2:2013  
EN 61000-6-2:2005, EN 61000-6-3:2007 + A1:2011  
EN 60335-1:2012 + A11:2014; EN 60335-2-103:2015  
50581-2012  
EN 13241-1:2003  
EN 12445:2002, EN 12453:2002, EN 12978:2003 (if applicable).

*The certificate of conformity in this document corresponds to the last review available at the time of printing and could differ for editorial requirements from the original available from the manufacturer.*

Benincà Luigi, Legal Officer.  
Sandrigo, 18/04/2018.

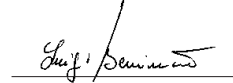

## EG-Konformitätserklärung (DoC)

Name des Herstellers: **Automatismi Benincà SpA**  
Adresse: **Via Capitello, 45 - 36066 Sandrigo (VI) - Italia**  
Telefon: **+39 0444 751030** E-Mail-Adresse: **sales@beninca.it**  
Zur Erstellung der technischen Dokumentation berechnete Person:  
**Automatismi Benincà SpA**

*Erklärt, dass das Dokument unter alleiniger Verantwortung herausgegeben wurde und zu dem folgenden Produkt ge-hört:*

Produkttypus: **Automation für Schiebetore**  
Modell/Typus: **BULL 17 OMI** Zubehör: **N/A**

*Das oben genannte Produkt stimmt mit den Vorschriften der folgenden Richtlinien überein:*

**Direttiva 2014/53/EU**  
**Direttiva 2011/65/EU**  
**Direttiva 2006/42/CE**

*Die harmonisierten Normen und technischen Spezifikationen, die unten beschrieben werden, wurden angewandt:*

ETSI EN 300 220-1 V3.1.1  
ETSI EN 300 220-2 V3.1.1  
ETSI EN 301 489-1 V2.1.1  
ETSI EN 301 489-3 V2.1.1  
EN 50950-1:2006 + A11:2009 + A1:2010 + A12:2011 + AC:2011 + A2:2013  
EN 61000-6-2:2005, EN 61000-6-3:2007 + A1:2011  
EN 60335-1:2012 + A11:2014; EN 60335-2-103:2015  
50581-2012  
EN 13241-1:2003  
EN 12445:2002, EN 12453:2002, EN 12978:2003 (Falls zutreffend).

*Die in diesem Dokument vorliegende Konformitätserklärung entspricht der neuesten zum Druckzeitpunkt erhältlichen Revision und könnte aufgrund von verlegerischen Gründen vom beim Hersteller erhältlichen Original abweichen.*

Benincà Luigi, Rechtsvertreter.  
Sandrigo, 18/04/2018.

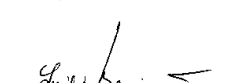

## Déclaration CE de conformité (DoC)

Nom du producteur : **Automatismi Benincà SpA**  
Adresse : **Via Capitello, 45 - 36066 Sandrigo (VI) - Italia**  
Téléphone : **+39 0444 751030** Adresse e-mail: **sales@beninca.it**  
Personne autorisée à construire la documentation technique :  
**Automatismi Benincà SpA**

*Nous déclarons que le document est délivré sous notre propre responsabilité et qu'il appartient au produit suivant :*

Type de produit : **moteur électromécanique pour portails coulissants**  
Modèle/Type: **BULL 17 OMI** Accessoires : **N/A**

*Le produit mentionné ci-dessus est conforme aux dispositions établies par les directives suivantes :*

**Direttiva 2014/53/EU**  
**Direttiva 2011/65/EU**  
**Direttiva 2006/42/CE**

*Les normes harmonisées et les spécifications techniques décrites ci-dessous ont été appliquées :*

ETSI EN 300 220-1 V3.1.1  
ETSI EN 300 220-2 V3.1.1  
ETSI EN 301 489-1 V2.1.1  
ETSI EN 301 489-3 V2.1.1  
EN 50950-1:2006 + A11:2009 + A1:2010 + A12:2011 + AC:2011 + A2:2013  
EN 61000-6-2:2005, EN 61000-6-3:2007 + A1:2011  
EN 60335-1:2012 + A11:2014; EN 60335-2-103:2015  
50581-2012  
EN 13241-1:2003  
EN 12445:2002, EN 12453:2002, EN 12978:2003 (le cas échéant).

*Le certificat de conformité présent dans ce document correspond à la dernière révision disponible au moment de l'impression et pourrait différer pour des exigences éditoriales de l'original disponible chez le constructeur.*

Benincà Luigi, Représentant Légal  
Sandrigo, 18/04/2018.

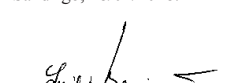

### Declaración CE de conformidad (DoC)

Nombre del productor: **Automatismi Benincà SpA**  
Dirección: **Via Capitello, 45 - 36066 Sandrigo (VI) - Italia**  
Teléfono: **+39 0444 751030** Dirección de correo electrónico: **sales@beninca.it**  
Persona autorizada a producir la documentación técnica:  
**Automatismi Benincà SpA**

*Declaro que el documento ha sido emitido bajo la propia responsabilidad y pertenece al siguiente producto:*

Tipo de producto: **motor electromecánico para cancelas correderas**  
Modelo/Tipo: **BULL 17 OMI** Accesorios: **N/A**

*El producto indicado arriba cumple con las disposiciones establecidas por las siguientes directivas:*

**Direttiva 2014/53/EU**  
**Direttiva 2011/65/EU**  
**Direttiva 2006/42/CE**

*Han sido aplicadas las normas armonizadas y las especificaciones técnicas que se describen a continuación:*

ETSI EN 300 220-1 V3.1.1  
ETSI EN 300 220-2 V3.1.1  
ETSI EN 301 489-1 V2.1.1  
ETSI EN 301 489-3 V2.1.1  
EN 50950-1:2006 + A11:2009 + A1:2010 + A12:2011 + AC:2011 + A2:2013  
EN 61000-6-2:2005, EN 61000-6-3:2007 + A1:2011  
EN 60335-1:2012 + A11:2014; EN 60335-2-103:2015  
50581-2012  
EN 13241-1:2003  
EN 12445:2002, EN 12453:2002, EN 12978:2003 (Si es aplicable).

*El certificado de conformidad presente en este documento corresponde a la última revisión disponible en el momento de la impresión y podría diferir por exigencias editoriales del original disponible en la sede del fabricante.*

Benincà Luigi, Representante Legal.  
Sandrigo, 18/04/2018.

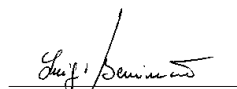

### Deklaracja zgodności CE (DoC)

Nazwa producenta: **Automatismi Benincà SpA**  
Adres: **Via Capitello, 45 - 36066 Sandrigo (VI) - Italia**  
Telefon: **+39 0444 751030** Adres e-mail: **sales@beninca.it**  
Osoba upoważniona do stworzenia dokumentacji technicznej:  
**Automatismi Benincà SpA**

*Oświadczam, że dokument został wydany na własną odpowiedzialność i dotyczy produktu:*

Rodzaj produktu: **Silnik elektromechaniczny do bram przesuwanych**  
Model/Typ: **BULL 17 OMI** Akcesoria: **N/A**

*Wyżej wskazany produkt spełnia wymagania dyrektyw:*

**Direttiva 2014/53/EU**  
**Direttiva 2011/65/EU**  
**Direttiva 2006/42/CE**

*Uwzględniono normy zharmonizowane i zastosowano niżej wskazane specyfikacje techniczne:*

ETSI EN 300 220-1 V3.1.1  
ETSI EN 300 220-2 V3.1.1  
ETSI EN 301 489-1 V2.1.1  
ETSI EN 301 489-3 V2.1.1  
EN 50950-1:2006 + A11:2009 + A1:2010 + A12:2011 + AC:2011 + A2:2013  
EN 61000-6-2:2005, EN 61000-6-3:2007 + A1:2011  
EN 60335-1:2012 + A11:2014; EN 60335-2-103:2015  
50581-2012  
EN 13241-1:2003  
EN 12445:2002, EN 12453:2002, EN 12978:2003 (Jeśli dotyczy).

*Certyfikat zgodności znajdujący się w niniejszym dokumencie odpowiada ostatniej aktualizacji dostępnej w momencie wydruku i może się różnić ze względów wydawniczych od oryginału dostępnego u producenta.*

Benincà Luigi, Przedstawiciel prawny.  
Sandrigo, 18/04/2018.

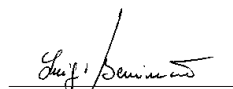



**BENINCA<sup>®</sup>**

**AUTOMATISMI BENINCÀ** SpA - Via Capitello, 45 - 36066 Sandrigo (VI) - Tel. 0444 751030 r.a. - Fax 0444 759728

---