

Beninca B17 Sliding Gate Operator

High Speed Industrial 240 Vac— for gates up to 1700 kg



The Beninca B17 sliding gate operator is a high quality European manufactured product designed to handle a wide range of commercial and industrial applications.

Ideally suited to situations with heavy duty gates requiring fast opening times.

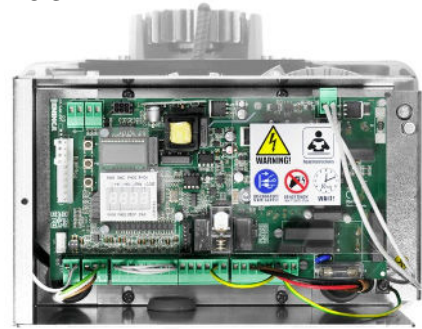

Control unit with built-in inverter, LCD display and encoder



Foundation plate with anchor bolts included. Motor and floor fixing distance 269 mm x 106 mm, no. 4 Ø 12 mm.



The HD heavy duty steel reinforced rack is supplied in 1m lengths 6 point fixing (legs down)

The Beninca B17 Sliding Gate Operator features:

- Single phase 240 Vac geared motor for intensive use
- The control panel, located under the cover on top of the motor, has an integrated inverter
- The control panel allows the installer a quick and easy way to program numerous functions simply by clicking through the intuitive menu
- The encoder ensures accurate positioning of the open and close cycles and controls the ramp up ramp down operation
- The diagnostic LCD display aids fault finding while the control panel monitors safety circuits to ensure correct and safe operation of the gate operator
- The manual release lever has a safety interlock that prevents the operator from starting while in manual mode
- The speed is adjustable from 10 to 24 m/min according to gate weight.

Weight (kg)	Speed (m/min)
1,700	17
1,000	20
500	24

Technical Specifications

Sliding Gate Operator	Beninca B17
Power supply	240 Vac (50-60 Hz)
Motor supply	240 Vac
Max absorbed current	7 A
Max thrust	1880 N
Max opening speed	24m/min
Duty cycle	80%
Protection level	IP44
Operating temperature	-20°C/+50°C
Lubrication	Oil
Max gate weight	1700 kg
Driving gear for rack	M4 Z18
Weight	21.6 kg

Dimensions

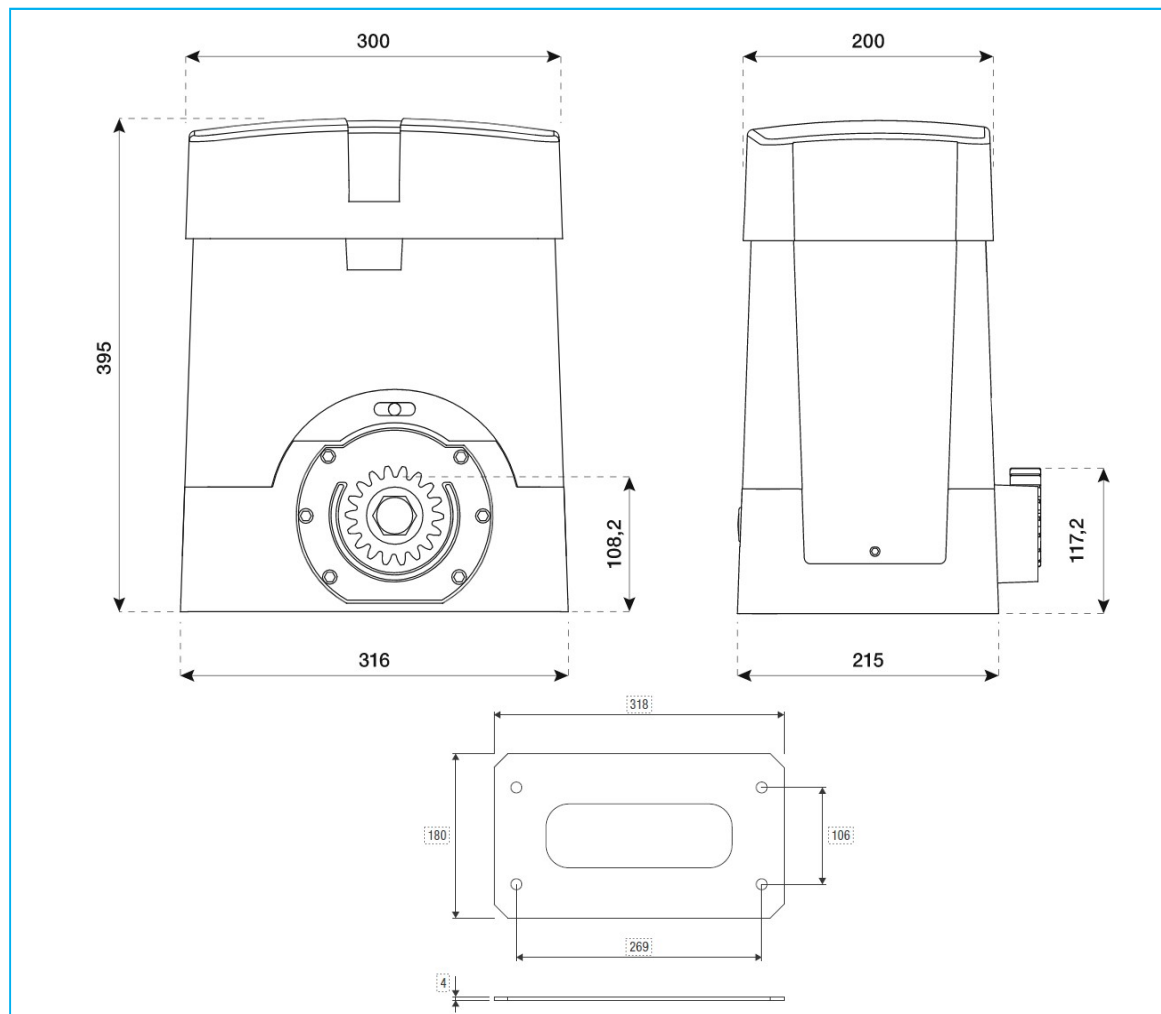

Rotech supply all forms of door and gate automation

Vehicle Access Control

- Booms Gates
- Sliding Gates
- Swing Gates
- Industrial Door Openers
- Solar Powered Gate Openers

Pedestrian Access Control

- Full Height Turnstiles
- Waist Height Turnstiles
- Supermarket Gates/Turnstiles
- Wheelchair Access Gates
- Rapid Access Gates

Fast | Safe | Secure

For more information: t: +61 07 3205 1123 | www.rotech.com.au | e: info@rotech.com.au

V0925