

Sentinel MB2 Manual Boom Gate

Manual barrier boom gate with innovative internal spring balance mechanism



The Sentinel MB2 Manual Boom Gates are ideal for use in applications where electrical power is not available or low use situations such as car yards, temporary installations on building sites and mine roads.



Designed to make light work of raising and lowering the boom pole Sentinel MB2 features an innovative internal spring balance mechanism to achieve this.

The manual boom gate is a cost effective solution compared to an automatic boom gate.

The Sentinel MB2 Manual Boom Gate features:

- **Actuating operating handle:** enables comfortable and easy handling of the boom pole.
- **Simple locking mechanism:** for convenience the pole can be locked in the open or close position using the thumbwheel located on the outside of the cabinet.
- **Secure:** If additional security is required a padlock can also be fitted to the catch post.
- **Balancing mechanism:** the easy to use boom gate has a spring that balances the pole and a catch post to hold the pole when closed reducing wear on the internal components.
- **Long lasting, strong and durable:** the cabinet is made from 3CR12 stainless steel and powder coated with a UV stabilised powder making it suitable for some of the harshest operating environments.
- **Low maintenance:** the boom pole is supported in heavy duty industrial bearings and requires little maintenance.

Technical Specifications

Specifications	Sentinel MB2 Manual Boom Gate
Cabinet Material	3cr12 Stainless Steel x 2.5 mm thick
Cabinet Dimension	140 x 122 mm
Boom Centre Height	968 mm
Weight	Cabinet 38 Kg Catch post 5.05 Kg
Colour	Traffic Yellow
Concrete Base	250 mm x 300 mm x 300 mm
Pole	3 m, 4.5 and 6 metre 76 mm round aluminium powder coated white with red reflective stickers

Dimensions

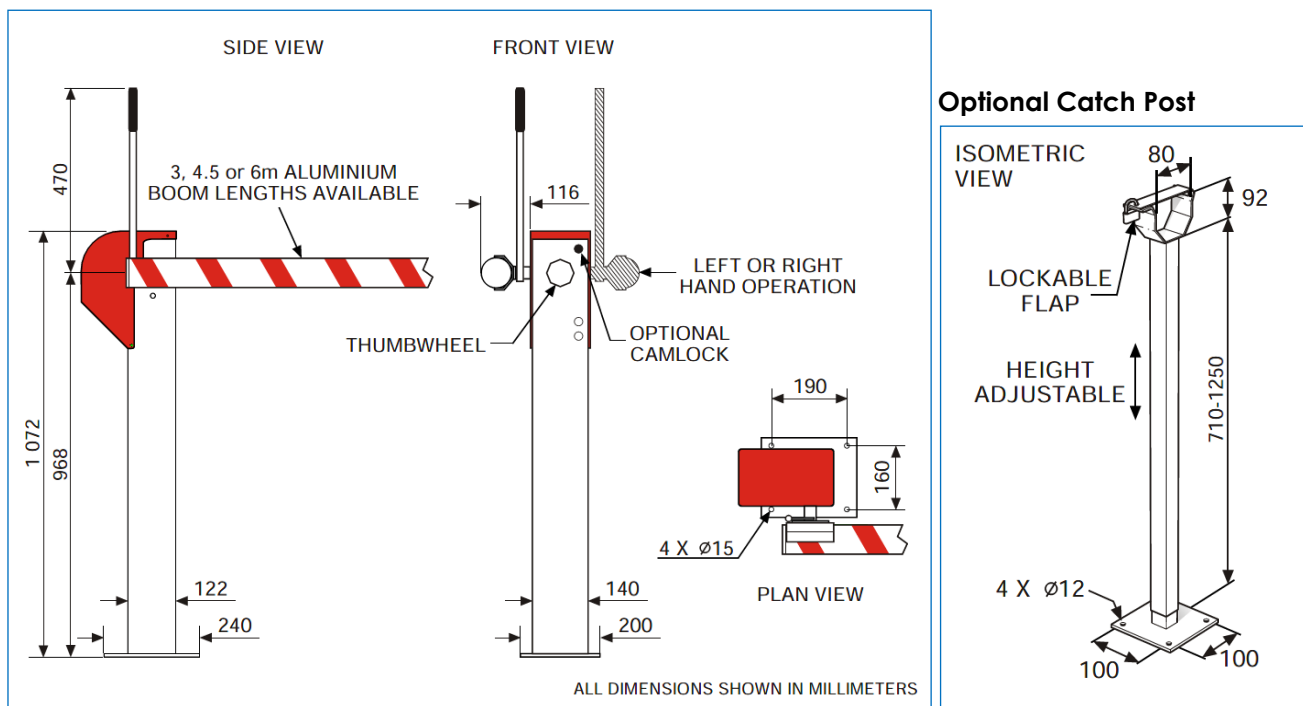

Mounting Dimensions

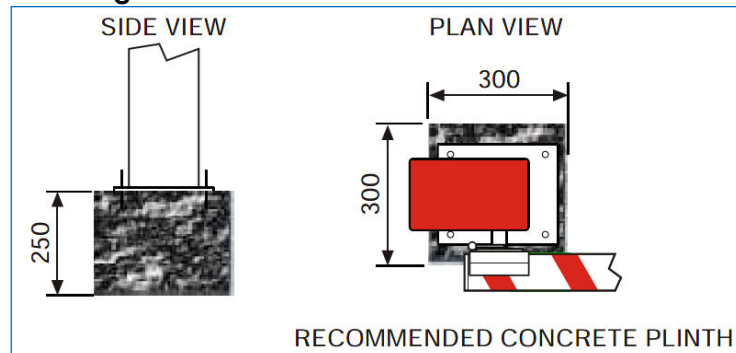

Rotech supply all forms of door and gate automation

Vehicle Access Control

- Booms Gates
- Sliding Gates
- Swing Gates
- Industrial Door Openers
- Solar Powered Gate Openers

Pedestrian Access Control

- Full Height Turnstiles
- Waist Height Turnstiles
- Supermarket Gates/Turnstiles
- Wheelchair Access Gates
- Rapid Access Gates

Fast | Safe | Secure

For more information: t: +61 07 3205 1123 | www.rotech.com.au | e: info@rotech.com.au

V2021