

F21 Full Height Turnstile Handing Diagram

F21 Turnstiles can be supplied as standard or non-standard as per below diagrams allowing the positioning of the Turnstile to be swapped to fit your entry/exit configuration.

Important Note: The handing configuration must be confirmed at time of order.

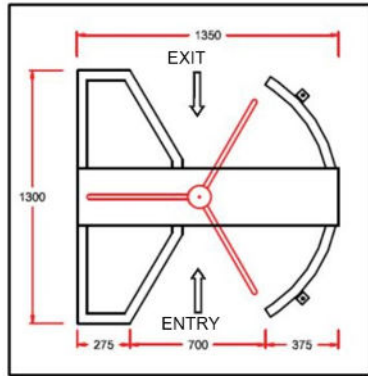

**STANDARD
TURNSTILE**

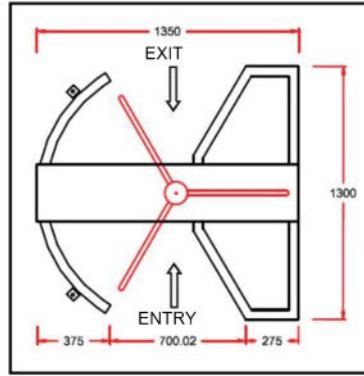

**NON - STANDARD
TURNSTILE**

MODE OF OPERATION OPTIONS

Although the F21 full-height turnstile features a built-in battery backup, ensuring up to 3,000 normal rotations in case of power failure the mode of operation can be adjusted to fit with your safety policy with the following options. **Please confirm mode of operation required at time of order.**

ENTRY	EXIT	OPTION 1 MOST POPULAR
LOCKED	LOCKED	NORMAL OPERATION
LOCKED	FREE	POWER FAIL WITH BATTERY BACKUP
LOCKED	FREE	POWER FAIL AND BATTERY FAIL
LOCKED	FREE	FIRE ALARM ON BATTERY
LOCKED	FREE	FIRE ALARM AND BATTERY FAIL
ENTRY	EXIT	OPTION 2
LOCKED	LOCKED	NORMAL OPERATION
FREE	FREE	POWER FAIL WITH BATTERY BACKUP
FREE	FREE	POWER FAIL AND BATTERY FAIL
FREE	FREE	FIRE ALARM ON BATTERY
FREE	FREE	FIRE ALARM AND BATTERY FAIL
ENTRY	EXIT	OPTION 3
LOCKED	LOCKED	NORMAL OPERATION
LOCKED	FREE	POWER FAIL WITH BATTERY BACKUP
LOCKED	LOCKED	POWER FAIL AND BATTERY FAIL
LOCKED	FREE	FIRE ALARM ON BATTERY
LOCKED	LOCKED	FIRE ALARM AND BATTERY FAIL

F21 FULL HEIGHT TURNSTILE FOOTING REQUIREMENTS

The concrete pad should be 20Mpa (min) 150 mm thick cured for 7 days on a suitably compacted foundation. Hold down anchors (6) to be 10mm dia x 75mm into the concrete.