

# F21 Full Height Turnstile

Built in Battery back-up system and optional solar power



*The Australian made F21 full-height bi-directional turnstile has been designed and manufactured by Rotech Automation over 10 years ago! It's design has evolved over the years to incorporate customer feed back and technology enhancement.*

It comes with battery back-up as a standard feature ensuring safety and security is maintained at all times and its soft start and stop feature makes it easier to use than ever.

Fabricated and assembled in Queensland it will fit most site configurations and comes with various options: an anti climbing roof and a pedestrian gate, stainless steel or powder coating. With a portable base, solar power option, you can install the F21 almost anywhere.

The F21 also comes in a wider version (XL) or for specific sites can be custom designed with a Right or Left angle exit.



The F21 is a bi-directional turnstile with galvanised frame and rotor, stainless steel or powder coating are an option (please contact us for a quote).

**Rotor Mechanism:** The F21 turnstile incorporates a high capacity drive mechanism, for 100% duty cycle and with a throughput of 15 people per minutes, not ever compromising on speed or security.

**Internal height:** Up to 2100mm and wide entrance allowing for personnel wearing hard hats and carrying tools.

**Status Indication System:** The status indication system allows the user to see when the turnstile is closed and if the entry (or exit) is freewheeling. The emergency key release is also monitored.

**Unique Relay and Battery Back-up Operation:** On power failure the built-in relay automatically initiates the battery back up system and sets off a warning siren (95dB) or optional flashing light. The turnstile will then continue to operate for up to 3,000 cycles without main power.

## F21 Full Height Turnstile features and options:

### F21 Turnstile

- 5 year conditional guarantee on mechanical drive and frame
- Solar power for remote sites
- Card reader mounting brackets
- Anti Climbing Roof
- Operating Status Indicator
- Portable base with fork lift pockets
- Compactly packed to fit on a skid for transport

### Wide Access Pedestrian Gate:

- For bulky goods and wheelchair access
- Both left and right-hand opening for flexibility post-installation
- Mag Lock with 650kg holding force or door handle with key lock or keypad.
- Compact, weatherproof and robust yet discreet set of European made door closers and hinges.

## Technical Specifications

Specifications	F21 Turnstiles
Throughput	15 people per minute
Duty Cycle	100%
Current	1 Amp @ 240 VAC
High Capacity Mechanism	Mechanical pawl and rollers non-reversible after 33°
Solenoid	12V DC
Battery back up is standard	Operates as normal for 3000 Operations
***Power Failure Options without battery back up	<ul style="list-style-type: none"> <li>■ Locked entry - free exit</li> <li>■ Locked exit - free entry</li> <li>■ Locked in both directions</li> <li>■ Free wheel in both directions</li> </ul>
Head mechanism enclosure	IP66 Rating
Dimensions (WxDxH)	Packed: 1300x1350x2100 - 330kg Installed: 1300x1350x2275 - 330kg

\*Configuration must be selected at order and can't be changed on site.

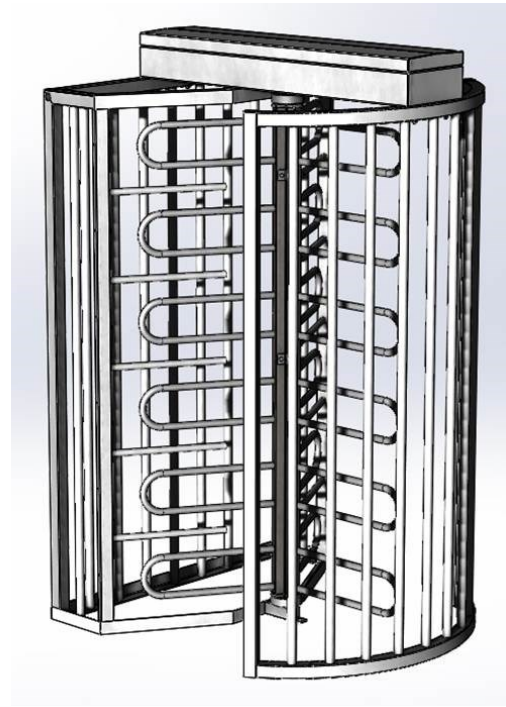

## Dimensions

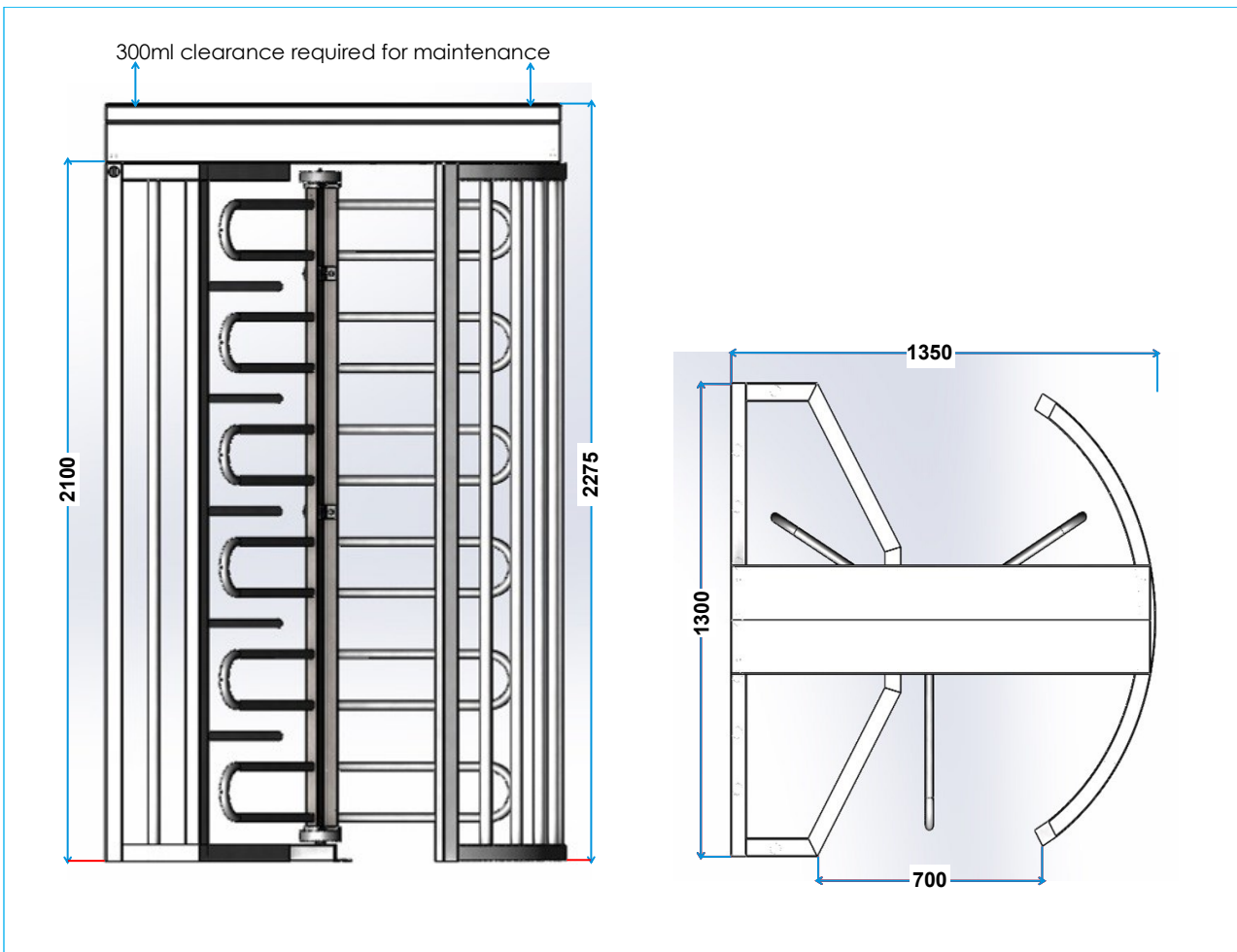

# F21 XL Access Full Height Turnstile

All the benefits of the Standard F21 but with extra wide entry

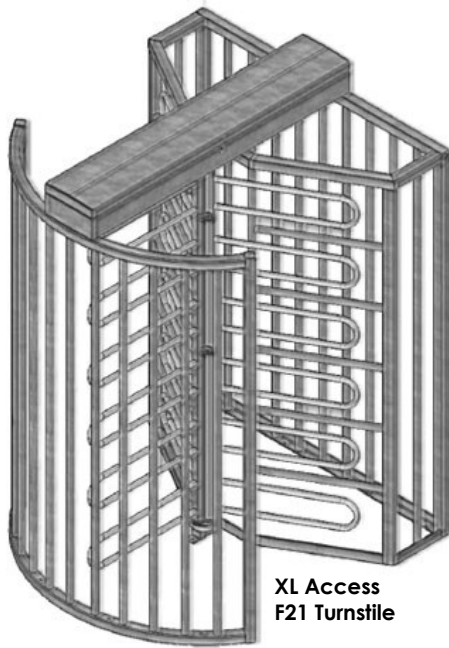

**XL Access  
F21 Turnstile**

The extra-wide version of the F21 offers additional space with an additional 131mm opening but without sacrificing security and still preventing "tailgating". It features wider rotors and a more spacious entry, making it easier to pass through the turnstile.

Ideal for entries where a pedestrian gate is not possible and where cumbersome packages or where a wider passage is required.

All other technical specifications remain the same as the standard size F21.

## Dimensions

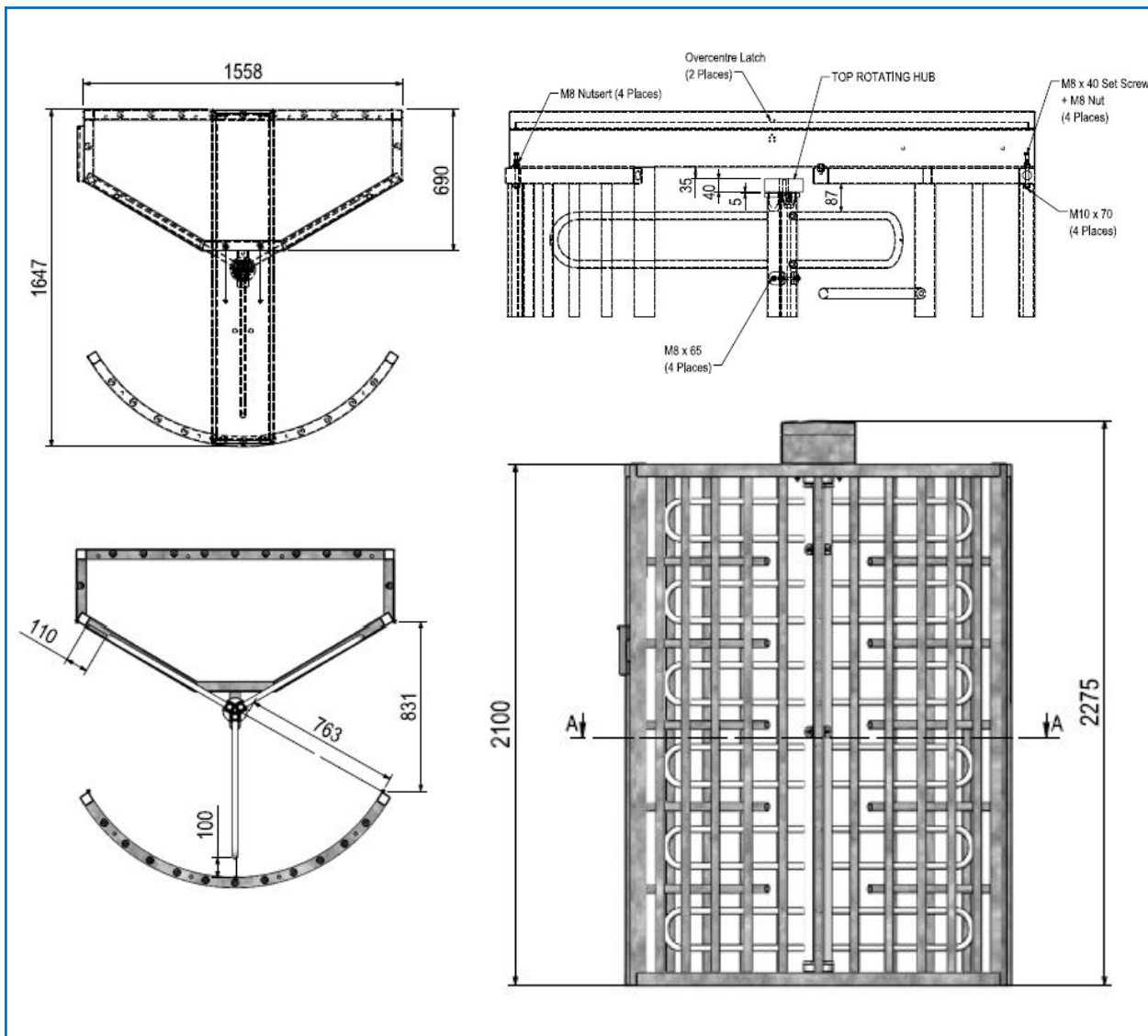

# F21 Full Height Turnstile with Pedestrian Access Gate

Gate construction compliments the turnstile design



The pedestrian access gate is designed to allow access for wheelchairs or larger and cumbersome objects that cannot pass through the turnstile. Features include:

- **Universal left and right-hand opening:** The gate can be either left or right-hand opening, providing flexibility post-installation for directional functionality.
- **Material:** Galvanized iron, with Powder Coating and Stainless Steel option
- **Magnetic lock or door handle with key or keypad:** The gate can be fitted with a magnetic lock with a holding force of up to 650kg. The mag lock and hinges/closer are manufactured in Europe and increase durability operational security and safety.

## Dimensions

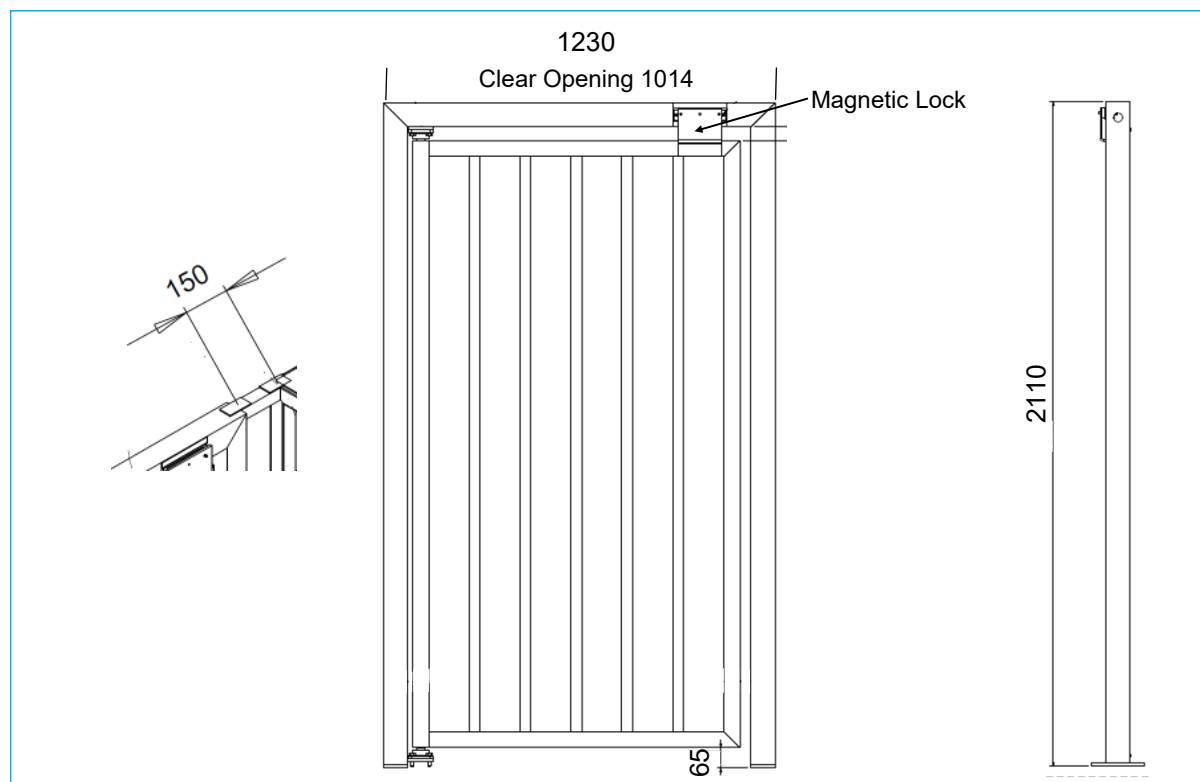

# F21 Full Height Turnstile: Custom Designs

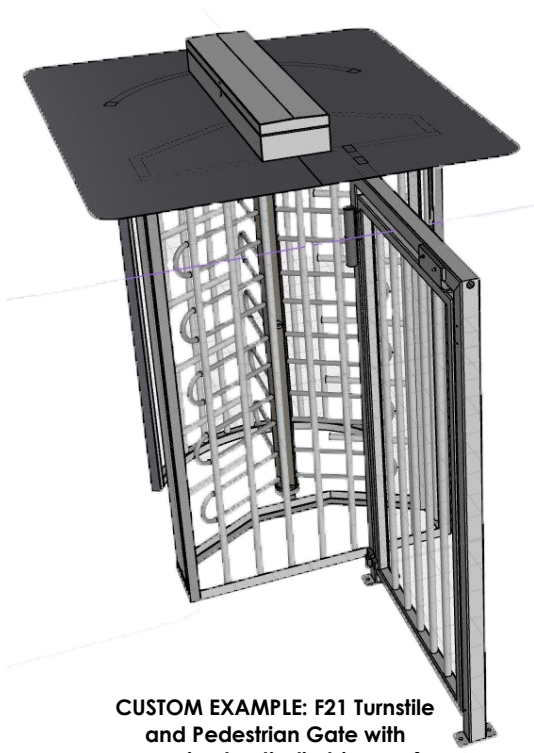

**CUSTOM EXAMPLE: F21 Turnstile and Pedestrian Gate with oversized anti-climbing roof**

Rotech F21 Full High Australia made Turnstile has been installed in over 100's of locations across Australia in the past 12 years. As the manufacturer of the F21 Rotech Automation can assist with a custom version to fit with your projects.

Should you require a right or left angle exit or are looking to have the turnstile incorporated in a cargo/ shipping container please give us a call and our team will work with you on a custom-made solution.

Whilst the standard version is always in stock and can be delivered in under 2 weeks, both the extra wide, customised version and stainless steel version can be delivered under 5 weeks.

Other combination with the pedestrian gates are also available: Double and gates, quad and gate (2 back to back + gate + 2 back to back)



**CUSTOM EXAMPLE: F21 Turnstile with right angle entry**

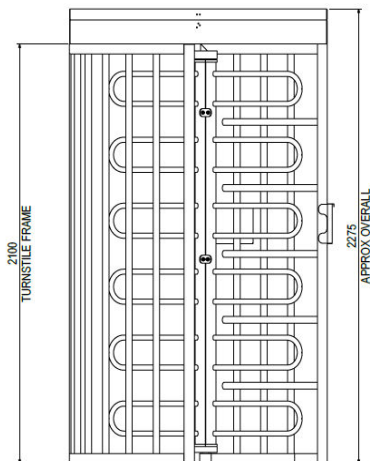
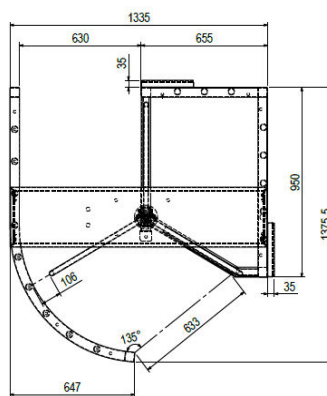

## Vehicle Access Control

- Booms Gates
- Sliding Gates
- Swing Gates
- Industrial Door Openers
- Solar Powered Gate Openers

## Pedestrian Access Control

- Full Height Turnstiles
- Waist Height Turnstiles
- Supermarket Gates/Turnstiles
- Wheelchair Access Gates
- Rapid Access Gates

**Fast | Safe | Secure**