

SafePass Warning Lights & Sounders

Rotech has access to a wide range of voice sounders, sirens and warning lights. Below are items that are available from stock, for any other requirements please contact us.

Amber High Profile Surface Mount Beacon



Stock Code: 584056

The Safe Pass amber high profile beacon is designed to get attention. With bright colour, intensity, and flashing rate it strongly delivers a sense of emergency.

With multiple settings, it also provides a 360-degree warning illumination for all emergency vehicles, tow trucks, warehouse forklifts and exit gates where extra safety is required.

Features

- ECE R10(EMC), SAE J845 Class 1 and CISPR 25 Class3 Certified, virtually no RFI/EMI radiation.
- Available in White and Amber Light
- Fully encapsulated for moisture, vibration and corrosion resistance.
- 32 pcs high-intensity LEDs to provide consistent warning performance.
- Aluminium die casting outer dome and extruded aluminium platform ensure stability during extended dwell time and long life dependability.
- Screw mounting includes 500mm cable.
- 11 optional flash patterns that can be customized.
- Magnet mounting model meets ISO-4148 standard.
- 2 mounting models available (Surface Mount, Magnet).
- 2 years warranty.



SIR-EJ and SIR-EJ LED Electronic Sounders and Strobe



Stock Code: 584061

Multi-function electronic sounder or sounder with red LED beacon combination

- 2 stage alarm on sounder version, output up to 105dB@1m
- 3 stage alarm on sounder-beacon version (flashing, flashing with sound, steady with sound)
- Tones include those meeting AS1670 and AS2220
- Surface mount with shallow or deep base
- Available in red or white body
- Multi-voltage 12-24v ac/dc
- IP65



Stock Code: 5840614

The flashing strobe light can be wired together or independent from the sounder enabling the sounder to be turned off while the flashing light remains activated. This keeps the alarm state present without the noise of a prolonged audible alarm.

Technical Specifications

Specification	Amber High Profile Beacon
Lens	Amber LED / Clear Lens
Profile	High profile -123mm height
Mounting	Surface Mount
Voltage	10-30V
Rating	ECE R65 Class 1/SAE J845 Class 1 ECE R10/CISPR 25 Class3
Warranty	2 Years
Weight	0.5000kg
Height x Width	Dia 120 x 123mm height

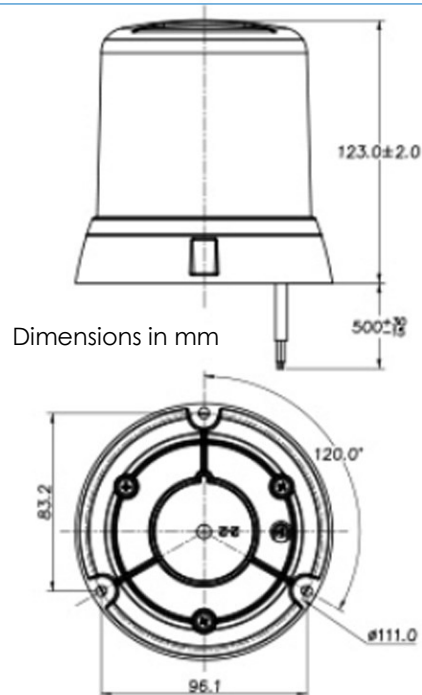

Specification	SIR-EJ and SIR-EJ LED Electronic Sounders and Strobe	
	Sounder Deep Base Red	Sounder/LED Deep Base Red/Red
Voltage	12-24VAC/DC	12-24VAC/DC
Current	215-250mA	300-350mA
Weight	0.26kg	0.37kg
Sound Output	105dB @ 1m	
Sound Frequency	SIR-EJ- 11 tones (2stages of 8 tones)	
Flash rate	3x85fpm ±10 or steady (Sounder-beacon version)	
Protection	IP65	
Duty	Continuous	
Temp rating (°C)	-30 to +50	
Cable Entry	M20 or through mounting base	
Construction	Polycarbonate	

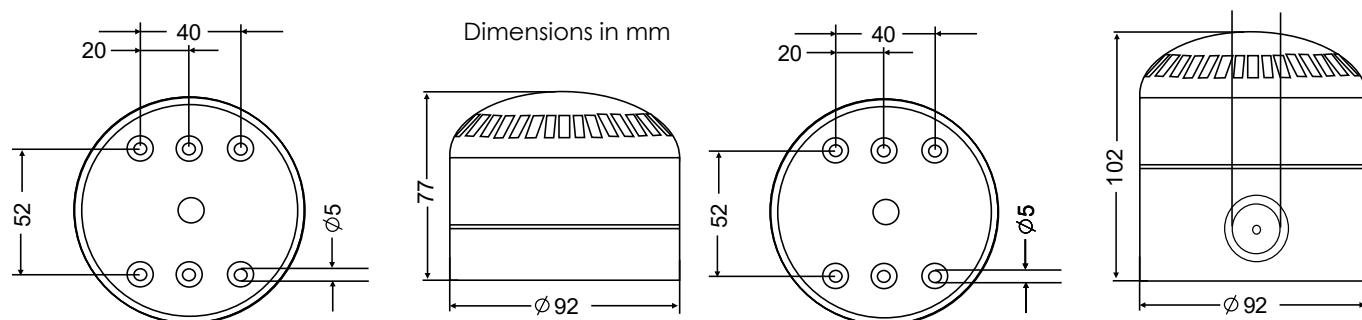

Rotech supply all forms of door and gate automation

Vehicle Access Control

- Booms Gates
- Sliding Gates
- Swing Gates

- Industrial Door Openers

- Solar Powered Gate Openers

Pedestrian Access Control

- Full Height Turnstiles

Fast | Safe | Secure