

Sentinel MB24 Articulated Arm Swing Gate Operator

European manufacture — fast, self-locking, intensive use 24 Vdc gate opener for gates up to 2.5m

Featuring a fast 10 second opening speed, the Sentinel MB24 articulated arm swing gate opener is suitable for domestic or commercial applications.



Single Arm (Standard)



Sliding Arm (Option)



Solar Powered Option



TO.GO4VA Transmitter



It's compact size, at only 184mm wide, makes the MB24 the ideal solution for gates with limited side spaces or gates with larger brick pillars that would struggle to fit the linear style gate opener.

The Sentinel MB24 Swing Gate Opener features include:

- **Quick easy installation**
- **Fast opening speed:** 10 secs
- **Integrated control unit:** the MB24's built-in control panel incorporates numerous operating functions
- **2 Limit switches:** equipped with open and close limit switches — can also be used for outward opening gates
- **Tough and durable:** equipped with a strong, articulated, anti-shearing arm and manufactured with tempered steel the mechanical quality of the Sentinel MB24 is excellent
- **Battery back up:** optional battery back up ensures operation can be guaranteed even in the event of a power supply failure
- **Optional solar power:** the ability to work on solar power makes the MB24 suitable for situations where mains power may not readily available or can be employed in temporary applications such as building sites, quarries or sports events
- **Safety sensing:** the obstacle detection system prevents damage to the gate and vehicles
- **Self-locking:** No lock required.

Technical Specifications

Specifications	Sentinel MB24 Swing Gate Opener
Power Supply	240 Vac
Motor Supply	24 Vdc
Max absorbed current	6.2 A
Torque	180 Nm
Opening time	10 seconds
Duty cycle	intensive use
Protection level	IP44
Built-in control unit	Yes
Operating temperature	-20°C /+50°C
Leaf max dimension	2.5 m
Weight	8.2 kg

Dimensions

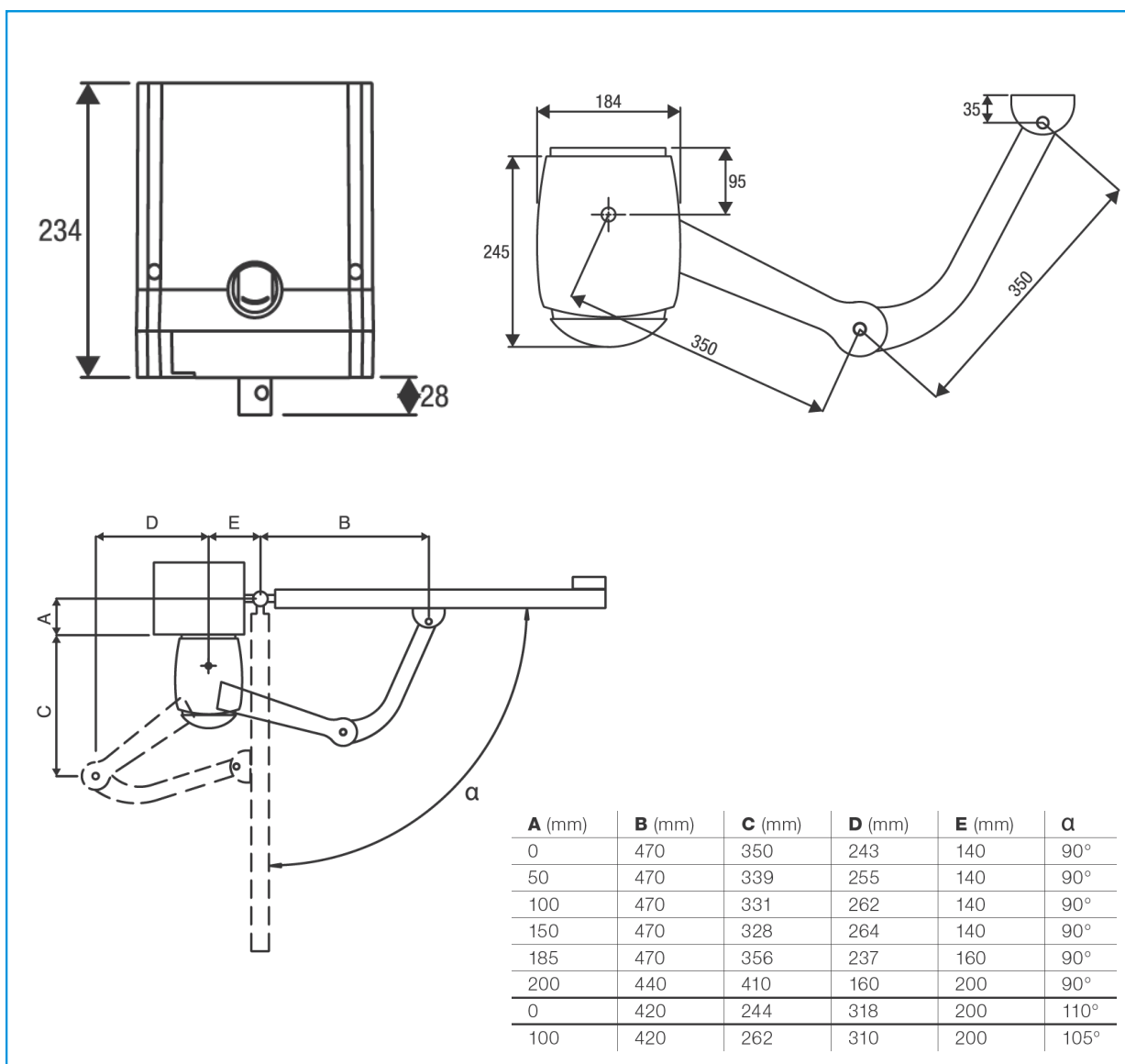

BRAINY24+ CONTROL PANEL

The Sentinel MB24 Swing Gate Operator is supplied with an in-built control panel as standard.

However, the Brainy 24+ can be added as an external control panel to accommodate other equipment such as loop detectors etc.

KEY FEATURES

- Suitable for use with 1 or 2 operators
- Built-in battery charger
- Integrated LCD display
- Integrated 433.92 MHz 64-code receiver
- Automatic, semi-automatic and deadman's control
- Separate limit switch inputs for each motor
- Open, close, step by step, pedestrian and stop inputs
- Output for electric lock 12 Vdc
- Output for configuration as second radio channel or service light
- Gate open indicator
- Separate electronic torque adjustment for each motor
- Anti-crushing safety through encoder management
- Separate adjustable slowdowns for each motor
- Advantouch system to configure parameters and manage radio transmitters
- Programming access password protected
- Maintenance warning
- Power supply: Control unit 24 Vdc – 50/60 Hz power supply; Motor 24 Vdc



Rotech supply all forms of door and gate automation

Vehicle Access Control

- Booms Gates
- Sliding Gates
- Swing Gates
- Industrial Door Openers
- Solar Powered Gate Openers

Pedestrian Access Control

- Full Height Turnstiles
- Waist Height Turnstiles
- Supermarket Gates/Turnstiles
- Wheelchair Access Gates
- Rapid Access Gates

Fast | Safe | Secure