

## Sentinel B12 Turbo for Sliding Gates up 1200 kgs

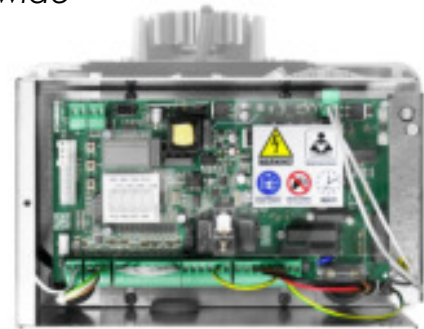

The Sentinel B12 Turbo 24vdc sliding gate operator is a high quality European manufactured product designed to handle a wide range of commercial and industrial applications.

Ideally suited to situations with heavy duty gates



Control unit with built-in inverter, LCD display and virtual encoder



Foundation plate with anchor bolts included. Motor and floor fixing distance 269 mm x 106 mm, no. 4 Ø 12 mm.



The HD heavy duty steel reinforced rack is supplied in 1m lengths 6 point fixing (legs down)

### The Sentinel B12 Turbo Sliding Gate Operator

- Single phase 240vdc geared motor for intensive use
- Built in battery charger
- The control panel, located under the cover on top of the motor, has an integrated inverter
- The control panel allows the installer a quick and easy way to program numerous functions simply by clicking through the intuitive menu
- The encoder ensures accurate positioning of the open and close cycles and controls the ramp up ramp down operation
- The diagnostic LCD display aids fault finding while the control panel monitors safety circuits to ensure correct and safe operation of the gate operator
- The manual release lever has a safety interlock that prevents the operator from starting while in manual mode
- The speed is adjustable from 10 to 24 m/min according to gate weight.

## Technical Specifications

| Sliding Gate Operator | Sentinel B12 Turbo |
|-----------------------|--------------------|
| Power supply          | 240 Vac (50-60 Hz) |
| Motor supply          | 240vdc             |
| Max absorbed current  | 3 A                |
| Max thrust            | 300 N              |
| Max opening speed     | 12.5÷24m/min       |
| Duty cycle            | 80%                |
| Protection level      | IP44               |
| Operating temperature | -20°C/+50°C        |
| Lubrication           | Oil                |
| Max gate weight       | 1200 kg            |
| Driving gear for rack | M4 Z18             |
| Weight                | 17.3 kg            |

## Dimensions

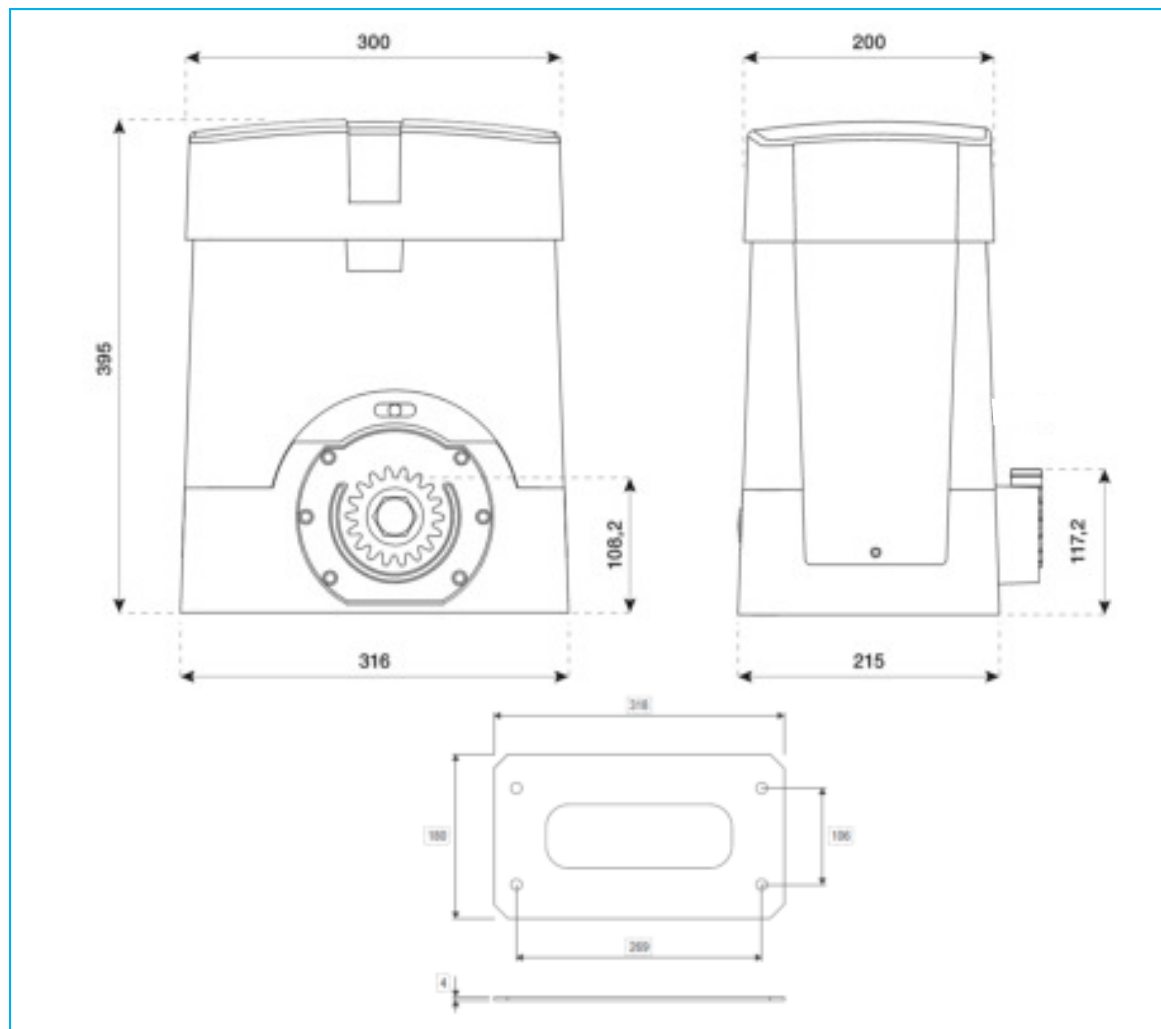

Rotech supply all forms of door and gate automation

### Vehicle Access Control

- Booms Gates
- Sliding Gates
- Swing Gates
- Industrial Door Openers
- Solar Powered Gate Openers

### Pedestrian Access Control

- Full Height Turnstiles
- Waist Height Turnstiles
- Supermarket Gates/Turnstiles
- Wheelchair Access Gates
- Rapid Access Gates

**Fast | Safe | Secure**

For more information: t: +61 07 3205 1123 | [www.rotech.com.au](http://www.rotech.com.au) | e: [info@rotech.com.au](mailto:info@rotech.com.au)

V0622