

Sentinel LD5 Automatic Boom Gate

100% duty cycle - 24v Intensive use traffic barrier



Features include built-in battery charger and external manual release.

Suitable for entrances up to 5 metres.

This is a quality European made boom gate which meets all international safety standards.

The Sentinel LD5 24 VDC intensive use automatic boom gate is easy to install and features a simple, fast and reliable boom balancing system.

The SIS accessory board enables a quick connection of master/slave boom gates.

The Sentinel LD5 provides the ability to install FTC.S photocells using concealed system for perfect integration.

The Sentinel LD5 Automatic Boom Gates features

- Electromechanical barrier for intensive use with control unit with battery charger and extended range switching power supply from 100 to 240 VAC, 50/60 Hz
- Integrated LCD display Removable terminal boards
- Automatic, semi-automatic and deadman's logic
- Motor limit switch inputs | Open, close, step by step, pedestrian and stop inputs
- Output for LD5 accessory, LED integrated on arm
- Output configurable as open barrier indicator light, second radio channel of incorporated receiver, arm light, service light, photocell test or maintenance indicator
- Predesigned for the operation of master/slave boom gates with SIS synchronisation board (optional)
- Automatic setting of operating parameters
- Anti-crushing safety thanks to amperometric obstacle detection
- Adjustable slow-downs
- Programming access password
- Maintenance warning
- Integrated battery charger, compatible with battery models DA.BT2/DA.BT6
- Reduced energy use on stand-by

Foundation plate not included

Technical Specifications

Sentinel Automatic Boom Gate	LD5 Metre
Power Supply	240V
Motor Supply	24V Vdc
Max absorbed current	1.5 A
Power consumption in stand-by	40 m/A
Torque	195 Nm
Opening time	3-6 Seconds
Duty Cycle	Intensive Use
Protection Level	IP44
Operating Temperature	+20°C / +50°C
Weight	50.8 kg

Terminal Connections

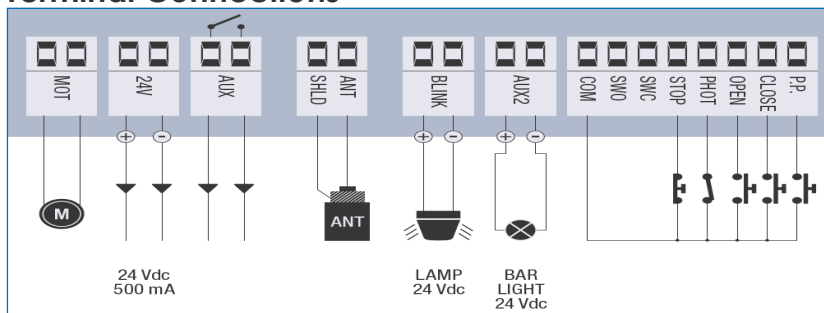

Dimensions

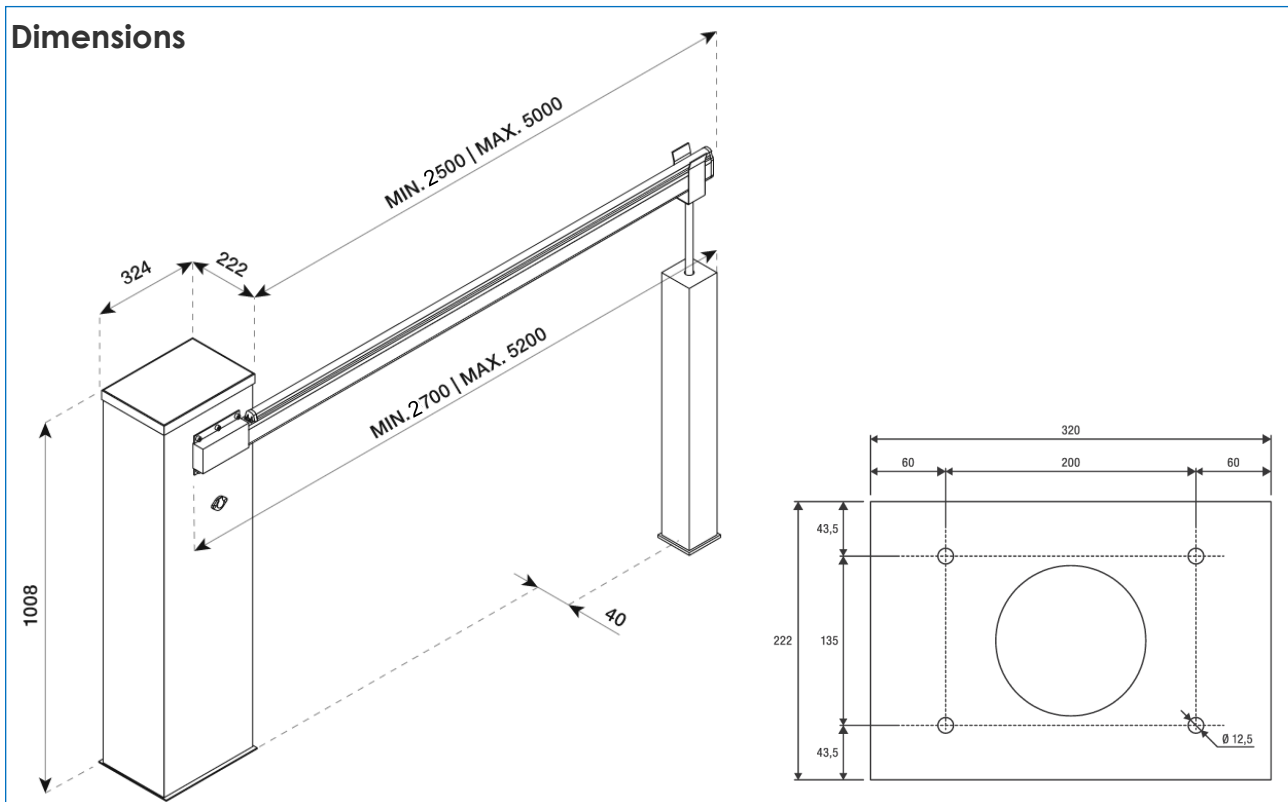

Rotech supply all forms of door and gate automation

Vehicle Access Control

- Booms Gates
- Sliding Gates
- Swing Gates
- Industrial Door Openers
- Solar Powered Gate Openers

Pedestrian Access Control

- Full Height Turnstiles
- Waist Height Turnstiles
- Supermarket Gates/Turnstiles
- Wheelchair Access Gates
- Rapid Access Gates

Fast | Safe | Secure

For more information: t: +61 07 3205 1123 | www.rotech.com.au | e: info@rotech.com.au

V0422