

Sentinel EVA 8 Metre Industrial Boom Gates

100% duty cycle - 24v Intensive use traffic barriers



Features include built-in battery charger and automatic testing of safety devices at each movement.

This is a quality European made boom gate which meets all international safety standards.

The Sentinel EVA intensive use automatic boom gates offer precise speed control, easily programmed multi-function digital controller and ultra responsive performance. Top access to the control panel allows easy and fast programming. The simple to adjust boom arm balancing system makes these boom gates quick and straight forward to install.

The Sentinel EVA 8 Metre Automatic Boom Gate features

- Electromechanical barrier for intensive use with control unit with battery charger and extended range switching power supply from 100 to 250 VAC, 50/60 Hz
- Integrated absolute encoder, which ensures greater precision in slowdowns and advanced control of the boom movement.
- This ensures that it never loses the reference position of the boom even if there is a power cut or the automatic device is released
- Integrated STC System for precise torque calculation
- Fast acting manual release in case of power failure
- Reduced energy use on stand-by
- Electronic collision sensing reverses boom pole on contact
- Right or left hand – the barrier can be easily re-handed.
- Optional flashing lights on boom arm
- 24 Vdc
- Battery back up charger included

Foundation plate not included.

Technical Specifications

Sentinel Automatic Boom Gates	EVA 8
Power Supply	240 Vac
Motor Supply	24V DC
Max absorbed current	1.6 A
Power consumption in stand-by	40 m/A
Torque	285 Nm
Opening time	3.5-6 seconds
Duty Cycle	Intensive Use
Protection Level	IP44
Operating Temperature	+20°C / +50°C

Dimensions

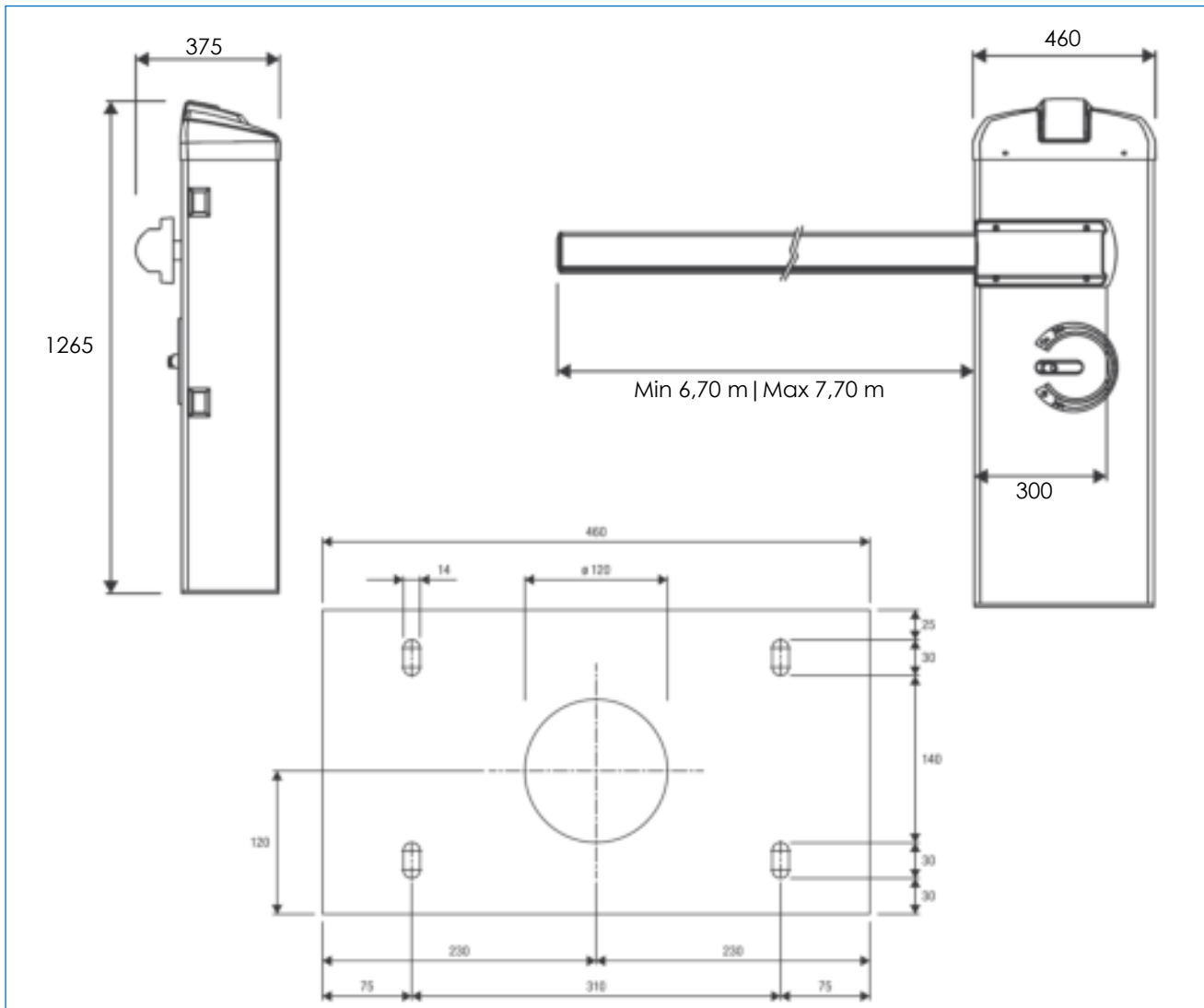

Rotech supply all forms of door and gate automation

Vehicle Access Control

- Booms Gates
- Sliding Gates
- Swing Gates
- Industrial Door Openers
- Solar Powered Gate Openers

Pedestrian Access Control

- Full Height Turnstiles
- Waist Height Turnstiles
- Supermarket Gates/Turnstiles
- Wheelchair Access Gates
- Rapid Access Gates

Fast | Safe | Secure

For more information: t: +61 07 3205 1123 | www.rotech.com.au | e: info@rotech.com.au

V0122