

Bionik BK 3-4 Metre Automatic Boom Gate

100% duty cycle - up to 5000 operations per day



Compact automatic boom gate for commercial and industrial applications.

The hi-tech Bionik BK boom gate's unique design offers precise speed control and ultra responsive operation in a compact design.

The BK's performance and features are equal to larger boom gates while its smaller size means it is ideal in situations where space is a premium.

Advanced features provide smooth operation, instant reversing, superior safety sensing, tough 100% duty cycle and low power consumption.

A new state-of-the-art solution, the Bionik BK automatic boom gate's strong, elegant, modern design and easily programmed multi function digital controller makes it perfect for apartments, commercial premises, industrial sites and residential areas.

The innovative brushless 36V motor with permanent magnetic field, combined with the new digital control unit, allows the Bionik BK to offer much more than larger boom gates.

The Bionik BK Boom Gate features include:

- **Compact design:** Smaller than regular boom gates the BK is engineered for optimum robustness and high stability during use.
- **Unsurpassed quality, tough and durable:** European designed and manufactured, the mechanical quality of the Bionik BK is exceptional. Featuring machined steel gears, high quality bearings, a strong gearbox and a self locking mechanism which prevents damage from the pole being forced.
- **Essential safety features are covered:** Strategically placed warning lights on the top of the cabinet are standard. Boom pole lights, loop detectors and safety beams options are also available ensuring vehicles and pedestrians alike are protected.
- **Speed control:** The absolute encoder constantly monitors the speed and position of the boom pole. The control unit accurately adjusts the opening and closing speed for smooth operation and longer life.
- **Increased safety sensing:** The motor design enables instant reversing of the boom pole if any safety devices are activated or if the pole is obstructed. Increased control of the safety sensing means all aspects of safety can be accurately managed.
- **Reliable and efficient:** The revolutionary brushless motor is more efficient - allowing up to 5000 operations per day with ultra low power consumption. The brushless motor saves time and money in maintenance.
- **Battery back-up:** For areas with power problems a battery back up automatically initiates on power failure—allowing the boom gate to function for up to 300 operations.
- **Solar power:** Allows the boom gate operate in temporary situations or areas without ready access to mains power.
- **Security feature:** The Bionik BK's intelligent control panel software can instantly lowers the pole to half-way to prevent tailgating.

PRODUCT FEATURES

Bionik BK Automatic Boom Gate

RELEASE KEY

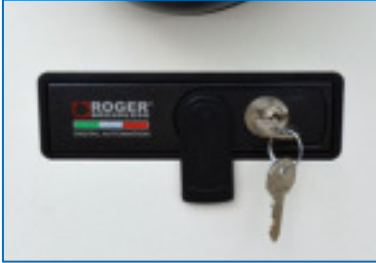

Easily operated emergency release key disengages the drive system without the need to open the cabinet. No danger to personnel from contact with electrical equipment or drive mechanism.

LED LIGHTING

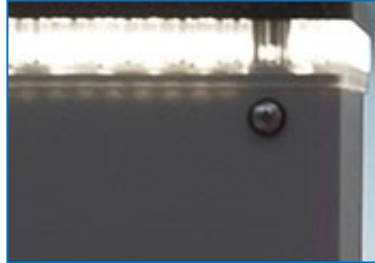

LED flashing lights around the top of the cabinet provide a warning to motorists and pedestrians that the boom gate is operating.

CONTROL UNIT

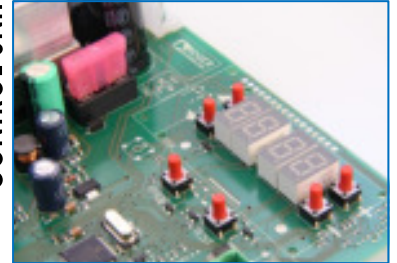

Easy to set up large LCD display with multiple functions. Speed control, ramp up and down, safety sensing are all stored in the memory. No relays on board make the unit very reliable.

ELLIPTICAL POLE

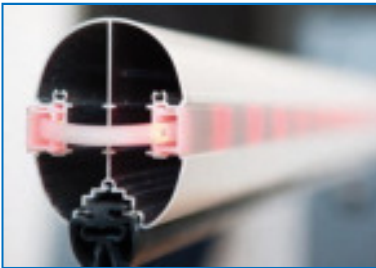

The strong elliptical pole section and center rib, ensure stability in high winds. LED flashing lights are an option.

BRUSHLESS 36V



The revolutionary and innovative brushless digital motor with permanent magnetic field. Allows intensive use with the benefit of ultra low power consumption.

GEAR BOX



Steel machined gears assembled with high quality bearings are rigorously tested to ensure precision movement and a long life.

ENCODER



The advanced innovative and precise Absolute Encoder is assembled on the slow shaft of the motor. It monitors the safety sensing circuit hundreds of times a minute allowing for instant reverse of the boom pole.

BALANCING SYSTEM



A durable, high quality spring efficiently balances the boom pole. The spring is rated for over 3 million operations.

ALLOY ARM



The pole drive arm is made from a special high strength alloy that fits inside the elliptical pole which reduces vibration in the cabinet and also damage from vandalism.

PRODUCT ACCESSORIES

Bionik BK Automatic Boom Gate

ADJUSTABLE POST



FOOT MOUNTED ADJUSTABLE SUPPORT POST: This sturdy post supports the boom pole and the height is adjustable on site to allow for kerbs or uneven roadways.

FOLDING POST



FOLDING SUPPORT POST: This support post is mounted on the boom pole and has a height adjustable leg. That maintains the pole in a horizontal position.

ARTICULATED ARM

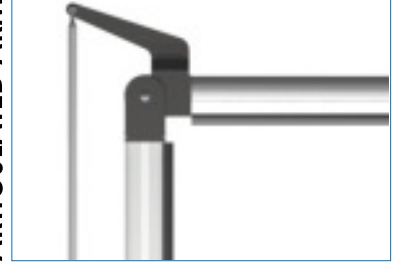

ARTICULATED ARM FOR LOW CEILING HEIGHT APPLICATIONS: The articulated arm is used where there is a height restriction such as underground garages.

PHONE CONTROL



GSM MOBILE PHONE CONTROL: The G-ULTRA module can be programed to accept up to 1500 different mobile numbers. When the module receives a call from a registered mobile it will open the boom gate but does not incur any call charges.

RADIO CONTROL



RADIO CONTROLS: The Nova code hopping radio controls offer convenience and security. They can operate at up to 80 metres and 250 transmitters can be coded into one receiver.

LOOP DETECTOR



LD 142 LOOP DETECTOR: A loop detector with cutting edge technology to provide selectable parameters, all programmable from the buttons on the front panel. The LD 142 has all the functions of a normal loop detector plus flexibility and acts as a loop analyser.

FENCE

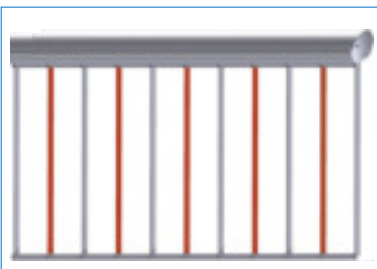

A fence is often used to stop pedestrians gaining entry under the boom pole. In areas where there are numerous pedestrians it is advisable to also fit a warning device such as a buzzer or flashing light.

CARD ACCESS



RFID CARD ACCESS CONTROL: The M1000 controller is a basic system designed to operate two boom gates. It is a stand alone system and can easily be programed to void cards using the LCD display on the unit.

TRAFFIC LIGHTS



LED TRAFFIC LIGHTS: There are two sizes available 100 mm and 200 mm diameter. For access control situations red / green is normally preferred but red / green/ amber are also available.

Technical Specifications

	Bionik BK
Boom Pole Length	3 metre or 4 metre
Cycles per day (opening/closing 24h non stop)	5,000
Opening Time	2 – 6 or 3 - 6 (sec)
Accessories power supply	24V DC
Manual Release	External with key
Power Supply	230V AC 10 AMP
Brushless motor power supply	From 0 to 36V DC
Motor Current	From 0 to 15A
Motor power	200W
Output Torque	From 0 to 200 Nm
Operating temperature	- 20 + 55 C°
Protection Level	IP54
Battery back up	(optional)
Master/Slave	Yes
Travel control system	Digital Absolute Encoder

Dimensions

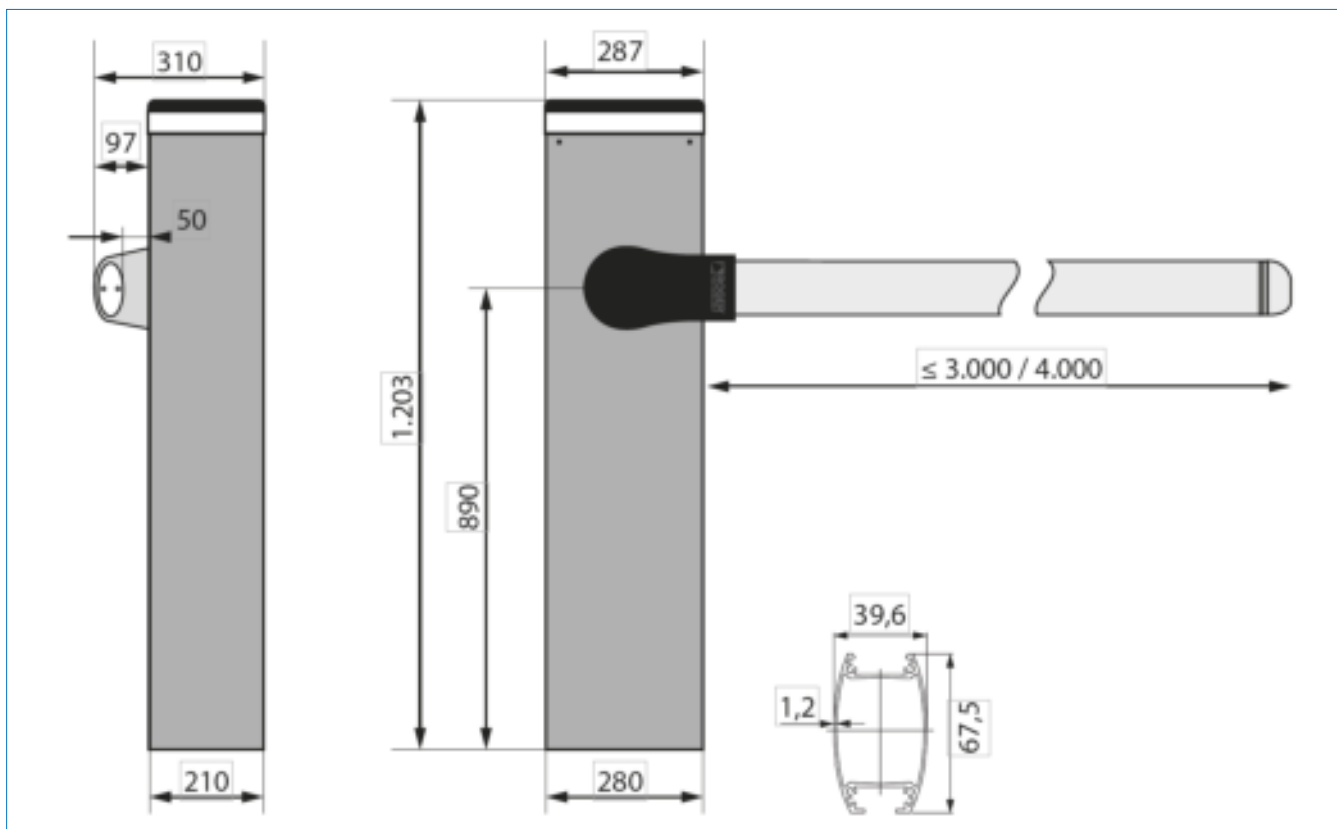

Rotech supply all forms of door and gate automation

Vehicle Access Control

- Booms Gates
- Sliding Gates
- Swing Gates
- Industrial Door Openers
- Solar Powered Gate Openers

Pedestrian Access Control

- Full Height Turnstiles
- Waist Height Turnstiles
- Supermarket Gates/Turnstiles
- Wheelchair Access Gates
- Rapid Access Gates

Fast | Safe | Secure

For more information: t: +61 07 3205 1123 | www.rotech.com.au | e: info@rotech.com.au

V0518