

Sentinel BG30 Series Sliding Gate Operators

Industrial operators, low voltage, 100% duty cycle for gates up to 2200 kgs



BG30/1804/HS for sliding gates up to 1800 kg
BG30/2204 for sliding gates up to 2200 kg

The BG30 Series sliding gate operators feature an advanced digital electromechanical brushless motor with native onboard encoder, built-in digital controller and 100% duty cycle.

Designed for super intensive use these operators offer maximum performance with the added benefit of low power consumption.

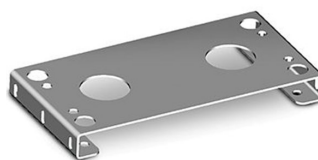

Raised fixing plate for easy installation

BG30 Series Sliding Gate Operator Features include:

- **Mechanically tough and durable:** precision engineering and high-quality steel worm shaft and bronze gears assembled with superior double-shielded ball bearings.
- **Increased safety sensing:** the design of the motor allows instant reversing of the gate if obstacle is detected.
- **Easy to program:** the multifunction digital display with 6 function keys makes it easy to change parameters, check error messages and input status.
- **Manual operation:** manually open your gate without removing the cover. Using the key to unlock the release lever and simply disengage the lever to push open the gate.
- **Increased safety sensing:** the highly sensitive digital encoder allows accurate control of speed and end stop positions.
- **Wide availability of inputs:** the digital controller offers a wide range of inputs for management and connection of all accessories and safety devices.
- **Strong and Robust:** made from a titanium alloy the BG30's high strength body can easily withstand the forces created by heavy high duty cycle gates with no affect on the operator.
- **Battery back-up:** battery back up is available for location where power supply is unreliable. This also gives peace of mind during storms or in the event of other power failure situations.
- **Solar Power Option:** for those areas where power is unavailable the BG30 sliding gate operator is configured to operate on solar power without any modifications to the controls.

Technical Specifications

Sliding Gate Operator	BG30/1804	BG30/2204
Gate Mass - maximum	1800kg	2200kg
Power line supply	230V AC - 50Hz	230V AC - 50Hz
Motor voltage	36V	36V
Power rating	650W	470W
Frequency of use	Intensive Use	Intensive Use
Thrust	50 - 1250N	50 - 1700N
Operating temperature	-20°C to + 55°C	-20°C to + 55°C
Gate Speed	18 m/min	10 m/min
Onboard control unit	B70/IDCHP	B70/IDCHP
Type exit gear	Z17/mod4	Z17/mod4
Operating cycles per day (opening/ closing 24 hours no stop)	800	1000
Gear Reductor type	Irreversible	Irreversible
Battery back up	Optional 2 external battery 12V 4.5AH	Optional 2 external battery 12V 4.5AH
Protection Level	IP43	IP43
Mass of unit packed	20.1kg	20.1kg
Solar power	Optional	Optional

Dimensions

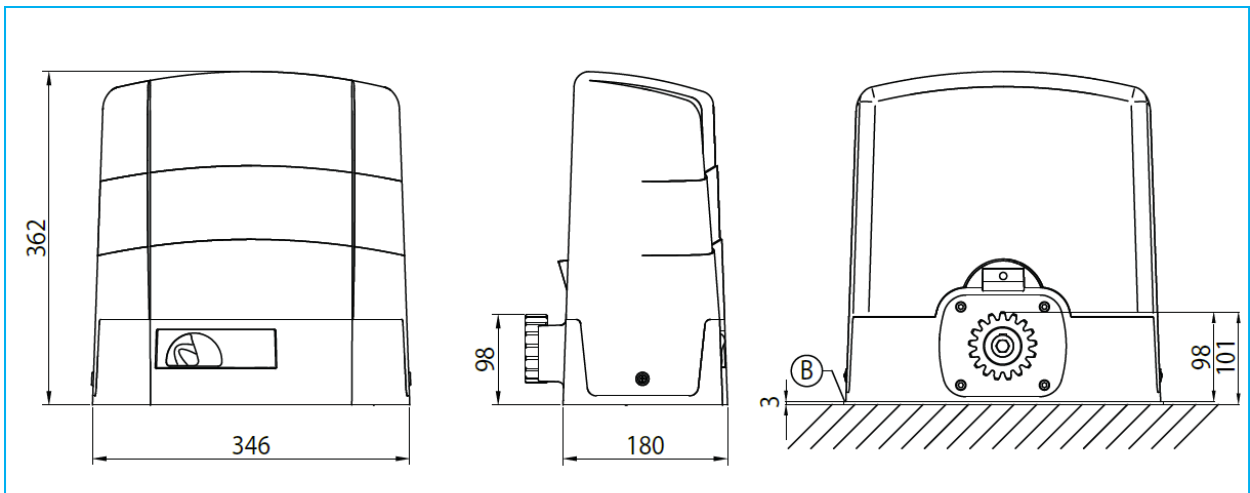

Rotech supply all forms of door and gate automation

Vehicle Access Control

- Booms Gates
- Sliding Gates
- Swing Gates
- Industrial Door Openers
- Solar Powered Gate Openers

Pedestrian Access Control

- Full Height Turnstiles
- Waist Height Turnstiles
- Supermarket Gates/Turnstiles
- Wheelchair Access Gates
- Rapid Access Gates

Fast | Safe | Secure

For more information: t: +61 07 3205 1123 | www.rotech.com.au | e: info@rotech.com.au

V0518