

Bionik AG 3-8 Metre Industrial Automatic Boom Gate

100% duty cycle - reinforced 3mm thick cabinet
- heavy duty springs and pole



The first automatic boom gate with digital thinking, the hi-tech Bionik AG boom gate's unique design offers precise speed control, easily programmed multi-function digital controller and ultra responsive performance.

Its advanced features provide a smooth operation, instant reversing, superior safety sensing, tough 100% duty cycle and low power consumption.

The new generation Bionik AG features strengthened pole support allowing it to operate reliably in 90 km/h winds.

The 8 metre AG has a 3mm thick reinforced cabinet, 2 x heavy duty springs and a boom pole with 2 internal braces making it suitable for all types of industrial applications.

The brushless motor combined with the new digital control unit enables the Bionik AG Series Boom Gate to offer so much more than regular boom gates.

The Bionik AG Boom Gate features include:

- **Quality is unsurpassed:** European designed and manufactured using only the highest quality materials and components available has produced a product that is strong, robust and designed to last.
- **Increased safety sensing:** The design of the motor will allow instant reversing of the boom pole if any of the safety devices are activated or if the pole is obstructed. Increased control of the safety sensing means all aspects of safety can be accurately managed.
- **Mechanically tough and durable:** the mechanical quality of the Bionik AG is exceptional, with machined steel gears and high quality bearings. The strong gearbox and self locking mechanism prevents damage from vandalism as the pole cannot be forced.
- **Essential safety features are covered:** Strategically placed warning lights on the top of the boom gate cabinet and the boom pole, loop detectors and 2 safety beams ensure vehicles and pedestrians alike are protected.
- **Speed control:** The absolute encoder constantly monitors the speed and position of the boom pole. This allows the control unit to accurately adjust the speed on closing and opening providing a smooth operation and longer life.
- **Security:** If tailgating is a problem the Bionik AG can solve this, the intelligent software of the control panel can prevent a second vehicle tailgating by instantly lowering the pole to half-way. The gate will not open until the second vehicle has taken a ticket or presented an access card.
- **Reliable and efficient:** The revolutionary brushless motor provides much greater efficiency - allowing up to 4000 operations per day with ultra low power consumption. Being brushless the motor saves time and money in maintenance.
- **Optional large capacity batteries:** can be fitted to increase operating times for solar power applications and when the mains fail.

PRODUCT FEATURES

Bionik AG Series Boom Gate

STURDY CABINET



The boom gate cabinet is strong, robust and very stable during operation. 3 mm steel plate zinc coated finished in white polyester UV resistant powder for long life.

LED LIGHTING



LED flashing lights on four corners of the cabinet provide a warning to motorists and pedestrians that the boom gate is operating.

CONTROL UNIT

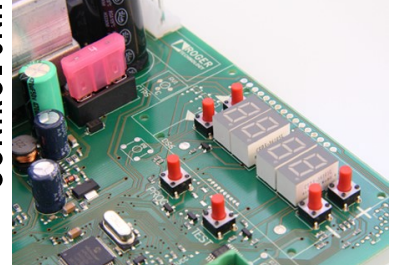

Easy to set up large LCD display with multiple functions. Speed control, ramp up and down, safety sensing are all stored in the memory. No relays on board make the unit very reliable.

ELLIPTICAL POLE

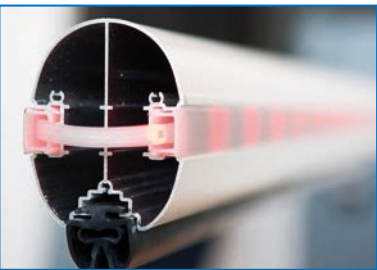

The strong elliptical pole section and center rib, ensure stability in high winds. LED flashing lights are an option.

BRUSHLESS 36V



The revolutionary and innovative brushless digital motor with permanent magnetic field. Allows intensive use with the benefit of ultra low power consumption.

GEAR BOX

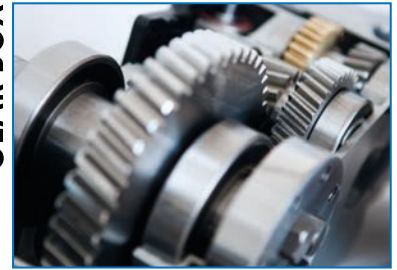

Steel machined gears assembled with high quality bearings are rigorously tested to ensure precision movement and a long life.

PROTECTIVE COVER



The pole protection cover rigidly secures the boom pole. The pole cover and top cover can be provided in different colours.

ENCODER

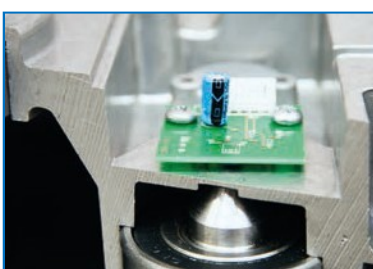

The advanced innovative and precise Absolute Encoder is assembled on the slow shaft of the motor. It monitors the safety sensing circuit hundreds of times a minute allowing for instant reverse of the boom pole.

BALANCING SYSTEM



The durable, high quality springs are supplied in different sizes to efficiently balance the boom pole. The springs are rated for over 3 million operations.

PRODUCT ACCESSORIES

Bionik AG Series Boom Gate

ADJUSTABLE POST



FOOT MOUNTED ADJUSTABLE SUPPORT POST: This sturdy post supports the boom pole and the height is adjustable on site to allow for kerbs or uneven roadways.

FOLDING POST



FOLDING SUPPORT POST: This support post is mounted on the boom pole and has a height adjustable leg. That maintains the pole in a horizontal position.

ARTICULATED ARM

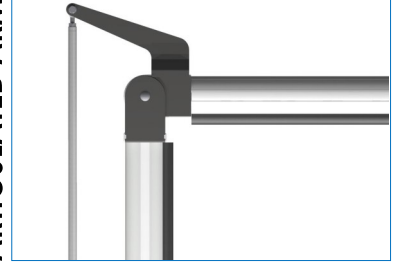

ARTICULATED ARM FOR LOW CEILING HEIGHT APPLICATIONS: The articulated arm is used where there is a height restriction such as underground garages.

PHONE CONTROL



GSM MOBILE PHONE CONTROL: The G-ULTRA module can be programmed to accept up to 1500 different mobile numbers. When the module receives a call from a registered mobile it will open the boom gate but does not incur any call charges.

RADIO CONTROL



RADIO CONTROLS: The Nova code hopping radio controls offer convenience and security. They can operate at up to 80 metres and 250 transmitters can be coded into one receiver.

LOOP DETECTOR



LD 142 LOOP DETECTOR: A loop detector with cutting edge technology to provide selectable parameters, all programmable from the buttons on the front panel. The LD 142 has all the functions of a normal loop detector plus flexibility and acts as a loop analyser.

FENCE

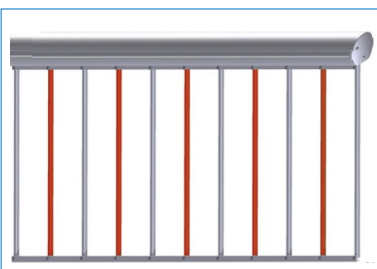

A fence is often used to stop pedestrians gaining entry under the boom pole. In areas where there are numerous pedestrians it is advisable to also fit a warning device such as a buzzer or flashing light.

CARD ACCESS



RFID CARD ACCESS CONTROL: The M1000 controller is a basic system designed to operate two boom gates. It is a stand alone system and can easily be programmed to void cards using the LCD display on the unit.

TRAFFIC LIGHTS



LED TRAFFIC LIGHTS: There are two sizes available 100 mm and 200 mm diameter. For access control situations red / green is normally preferred but red / green / amber are also available.

Technical Specifications

Bionik AG	AG-3M	AG-4M	AG-6M	AG-8M
Boom Pole Length	2800 from front of cabinet	3800 from front of cabinet	5800 from front of cabinet	7800 from front of cabinet
Cycles per day (opening/closing 24h non stop)	5,000	5,000	4,000	2,500
Opening Time	3 - 6 (sec)	3 - 6 (sec)	4 - 8 (sec)	9 - 29 (sec)
Accessories power supply	24V DC	24V DC	24V DC	24V DC
Manual Release	External with key	External with key	External with key	External with key
Power Supply	230V AC 50Hz	230V AC 50Hz	230V AC 50Hz	230V AC 50Hz
Brushless motor power supply	From 0 to 36V DC	From 0 to 36V DC	From 0 to 36V DC	From 0 to 36V DC
Motor Current	From 0 to 15A	From 0 to 15A	From 0 to 15A	From 0 to 18A
Motor power	200W	200W	200W	300W
Output Torque	From 0 to 200 Nm	From 0 to 200 Nm	From 0 to 300 Nm	From 10 to 400 Nm
Operating temperature	- 20 + 55 C°	- 20 + 55 C°	- 20 + 55 C°	- 20 + 55 C°
Protection Level	IP54	IP54	IP54	IP54
Battery back up	(optional)	(optional)	(optional)	(optional)
Master/Slave	Yes	Yes	Yes	Yes
Travel control system	Digital Absolute Encoder	Digital Absolute Encoder	Digital Absolute Encoder	Digital Absolute Encoder

Dimensions

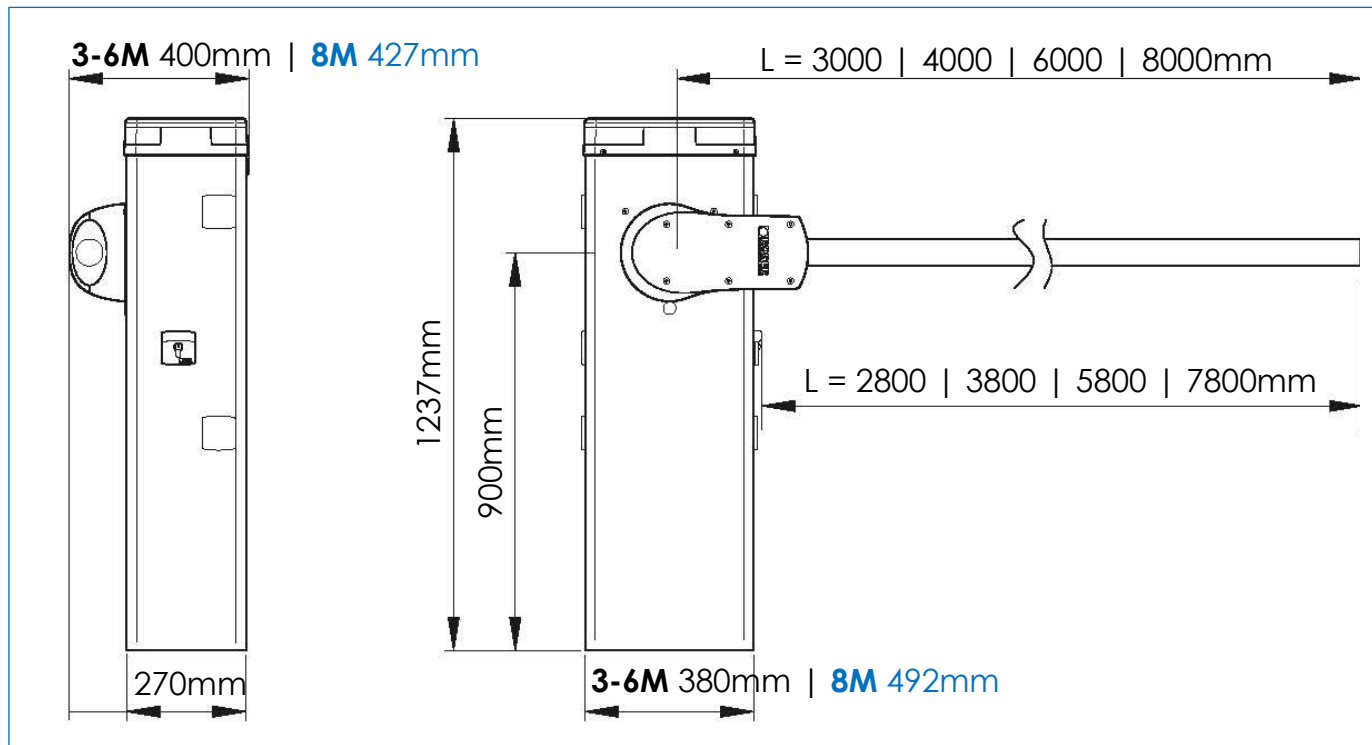

Rotech supply all forms of door and gate automation

Vehicle Access Control

- Booms Gates
- Sliding Gates
- Swing Gates
- Industrial Door Openers
- Solar Powered Gate Openers

Pedestrian Access Control

- Full Height Turnstiles
- Waist Height Turnstiles
- Supermarket Gates/Turnstiles
- Wheelchair Access Gates
- Rapid Access Gates

Fast | Safe | Secure

For more information: t: +61 07 3205 1123 | www.rotech.com.au | e: info@rotech.com.au

V0818