



Vehicle Access Control  
Pedestrian Access Control  
Safety & Security Equipment

T: +61 7 3205 1123

[www.rotech.com.au](http://www.rotech.com.au)

e: [info@rotech.com.au](mailto:info@rotech.com.au)

# F21 DN/DS FULL HEIGHT TURNSTILE

## (Mechanical Free Exit on Power Fail)

(v01/25)

## Installation Instructions



Please read these instructions fully before installing

## FH 21 Turnstile Main Components

The turnstile consists of six main components:

- Main Frame
- Sweep
- Header Box
- 3 x Rotor Arms.

The rotors only fit one way and the top of the rotor is marked **TOP**.

The Turnstile is supplied in knock down form on a pallet 1400 x 800 x 2300 and weighs 200kgs. One person can assemble the turnstile but it is advisable to use two people for safety reasons.

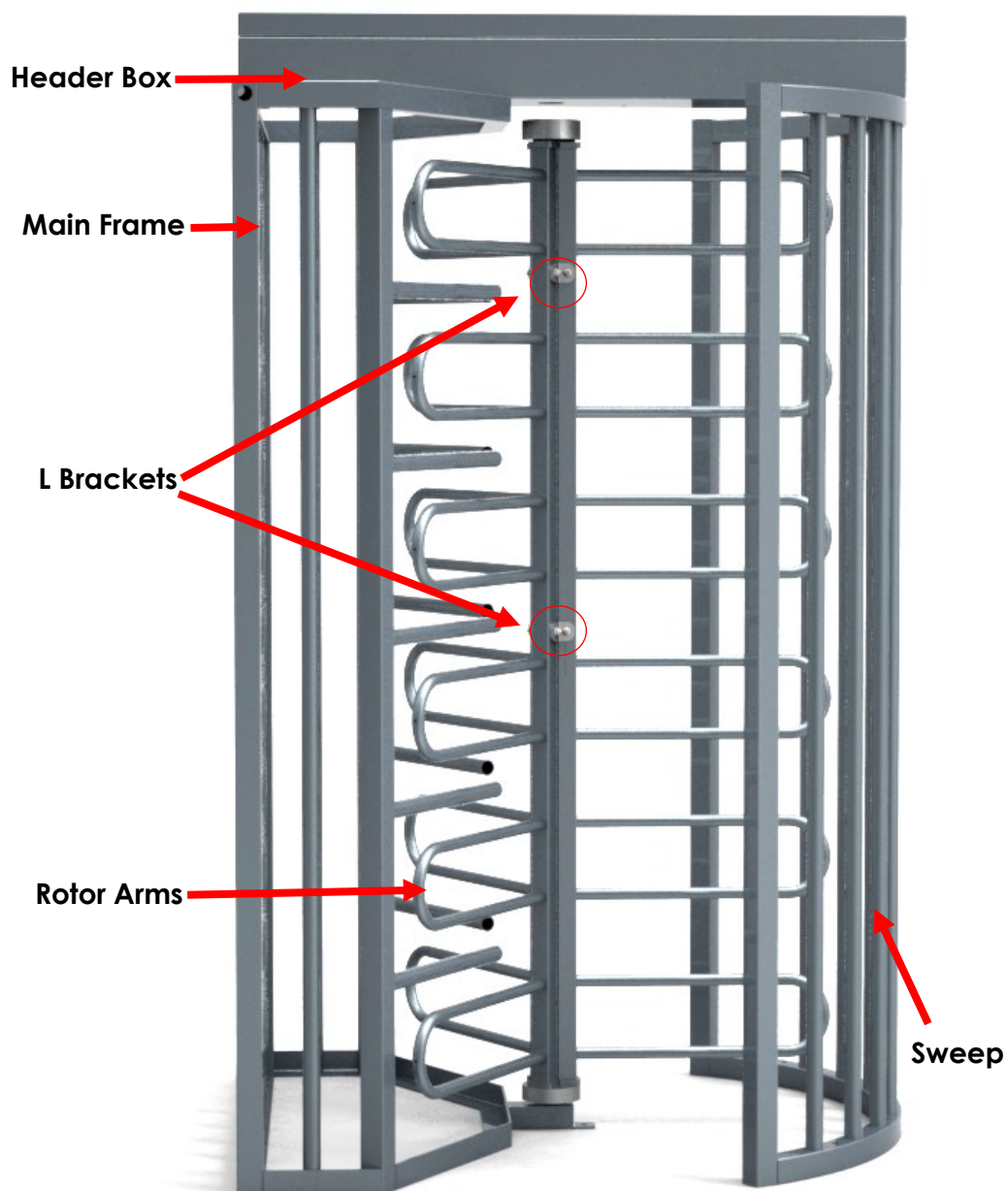

## Dimensions

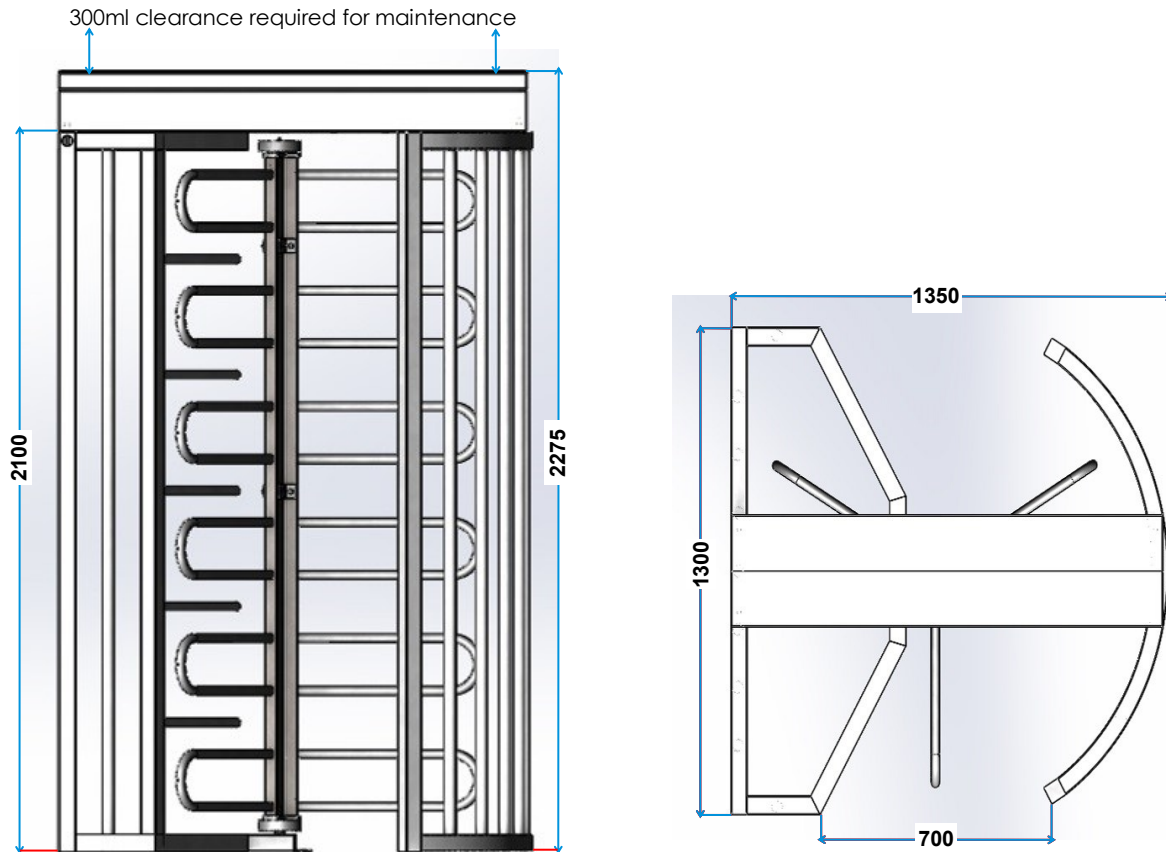

## Specifications

### Specification

- |                                    |  |
|------------------------------------|--|
| <b>1. Throughput:</b>              | 15 people per minute   |
| <b>2. Duty Cycle:</b>              | 100%   |
| <b>3. Mains supply:</b>            | 1 Amp @ 240 VAC  |
| <b>4. High Capacity Mechanism:</b> | Mechanical pawl and rollers non-reversible after 33°   |
| <b>5. Solenoid:</b>                | 4 AMPS @12V DC   |
| <b>6. Power Failure Options:</b>   | Battery back up is standard. Operates as normal for 3000 operations if no other accessories are connected.       |
|                                    | <b>NB:</b> The following options are only possible at the time of ordering and <b>cannot be changed on site:</b> |
|                                    | ■ Locked entry - free exit   |
|                                    | ■ Locked exit - free entry   |
|                                    | ■ Locked in both directions  |
|                                    | ■ Free wheel in both directions  |
| <b>7. Controller:</b>              | TL 100 B   |
| <b>8. Self locking time out:</b>   | Dip switch adjustable 3 –10 secs   |
| <b>9. Trigger Pulse:</b>           | N/O pulse 0.5 sec –1 sec maximum   |

## Installation Instructions

- Remove packaging, cable ties and disassemble.
- Open the header box and remove top and bottom flanges.
- Place the main frame into final position and bolt down, make sure it is square and level. This is **extremely important** as the rotor will not operate correctly if the frame is misaligned.
- Place the sweep in the correct position and bolt down, ensuring it is level.
- Lift header box into position and insert the 4 lengths 170 x 10 threaded rod into both ends of the header box and through the frame to prevent the header box falling while you jack it up.
- Fix 1 nut top and bottom of the stud. Jack up the header box using the 4 lengths of 8 x 250 threaded rod in the nutserts until it is 65 mm clear of the frame.
- Position lower rotor coupling (3 equal size blocks) onto the spigot on the main frame.
- Assemble rotor arms on the lower flange and tie together with cable ties. The rotors can only fit one way and the top is marked.
- Slowly lower the header box and engage the longest pin of the top coupling into the rotor arm, continue lowering and engage the other rotor arms.
- Tighten all bolts in the header box and rotate the arms. The arms should only require 2 kgs force to rotate freely and return to the default position. If the rotor is not free something is out of alignment, release the header box bolts and retry. If the problem persists you may need to use packers to level the sweep and /or the frame.
- Fit the two sets of "L" shape brackets onto the rotor arms and fasten securely, it is **extremely important** that these are secure.
- If they are not fitted or are loose it will damage the rotor couplings.

**NOTE: All electrical connections must be completed by a licensed electrician in accordance with Australian wiring regulations.**

- The cables can be fed to the header box via the holes provided in the frame.
- The power and control cables to the turnstile may be fed overhead, directly into the header box or alternatively from below in conduits from the slab and entering through the hollow members of the frame.
- Holes are provided to assist the installing of cables and plugs are provided to seal these holes.
- After the turnstile has been tested on mains power, it needs to be tested on the back up batteries. Disconnect the mains supply connect the red cable to POSITIVE on battery 1 and NEGATIVE on battery 2. Then test without mains connected if test is OK leave the battery connected.
- Do not attach any other equipment to the batteries or operate the turnstile without mains power except in an emergency. As this will run down the batteries.

# Operation

- The controller is triggered by a momentarily closed contact for + / - 0.5 to 1 second. (It must not be longer than 1 second.) The solenoid unlocks the pawl to allow the rotor to rotate through 120°.
- Once past the 60° position the rotor can not be reversed to allow the person to back out.
- When the rotor has passed the 60° position the limit switch cam cancels the timer controlling the locking pawl and the turnstile locks itself.
- If a person does not proceed through the turnstile the timer will time out and lock the turnstile after a pre-set time.

**IMPORTANT: the fire release function uses battery power to energise the exit solenoid. Therefore the batteries should be periodically tested and replaced as required. The standard batteries are 2x7 Ahr AGM.**

## Wiring Diagram 1: Mechanical Free Exit with Battery Charger (701DS/DN)

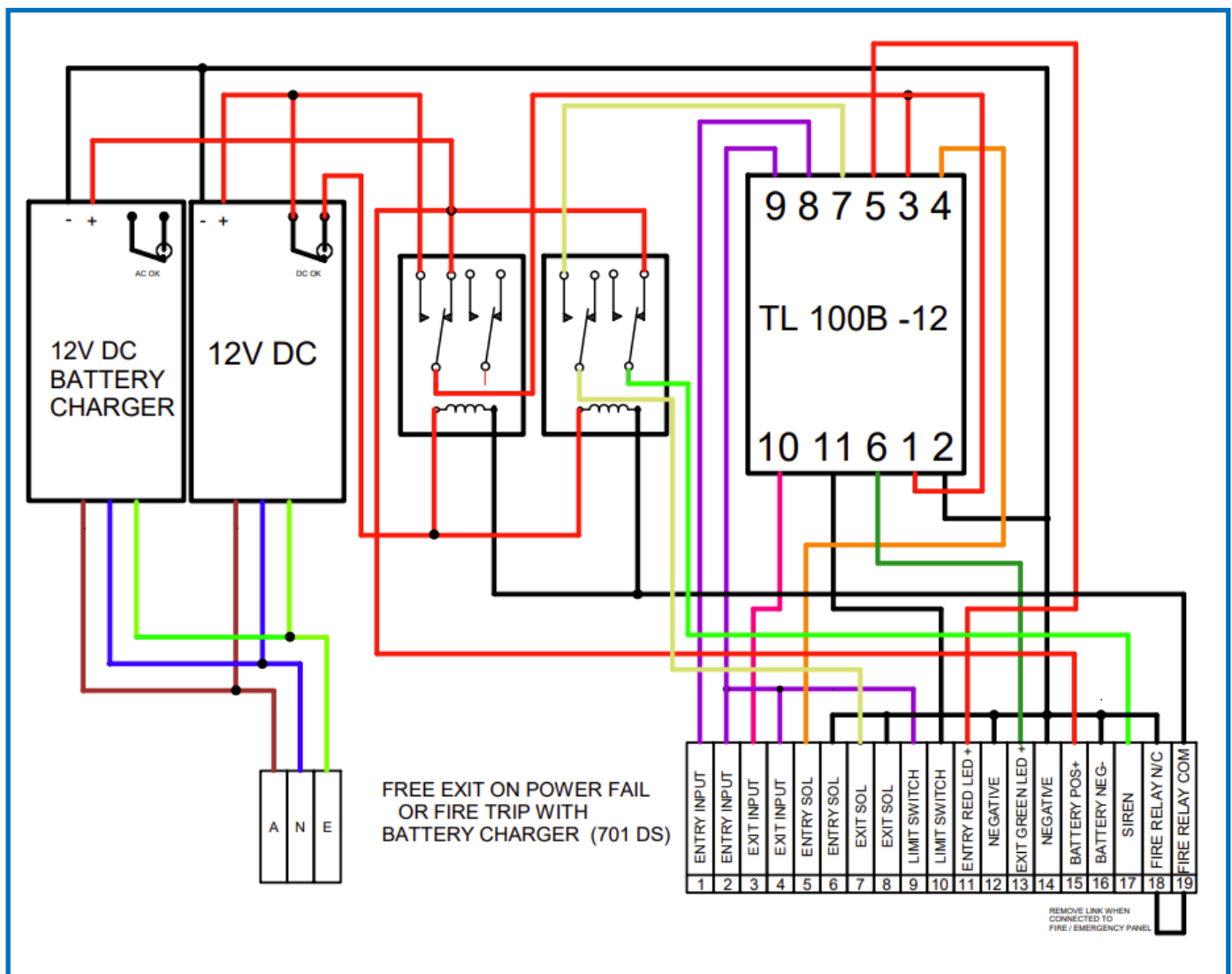

# F21 TURNSTILE (STANDARD)

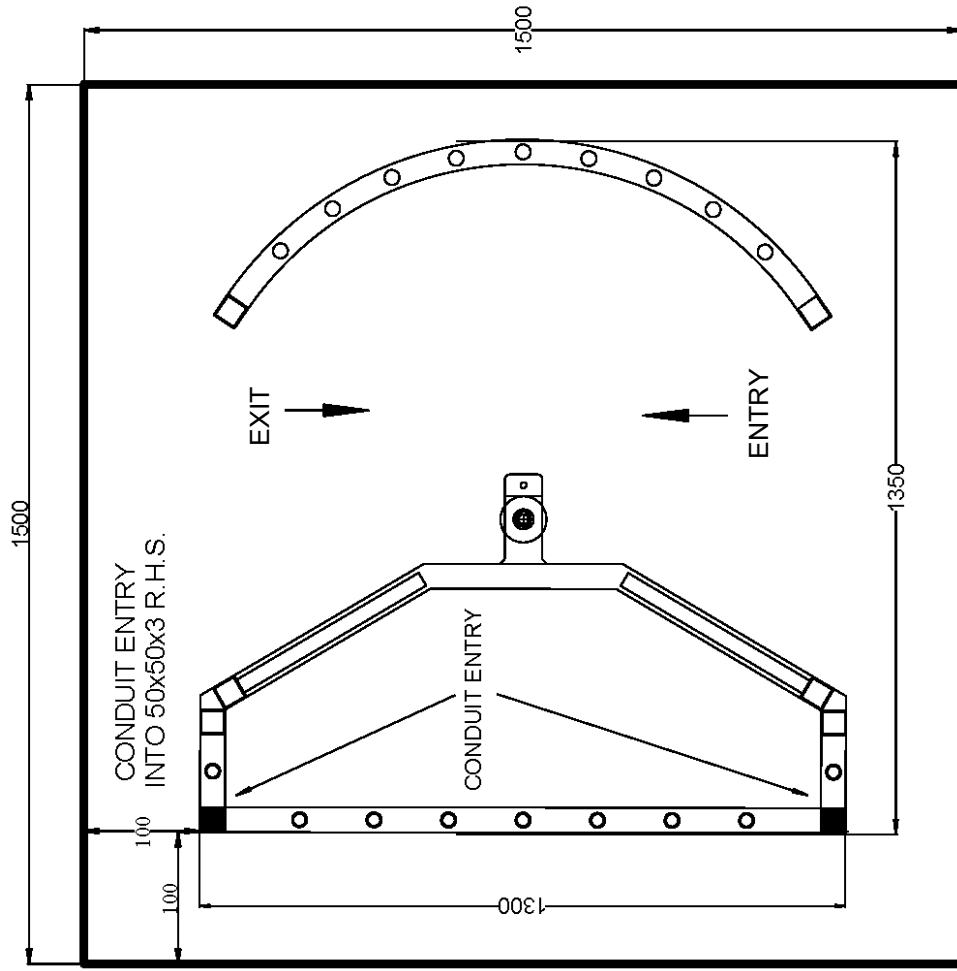

## IMPORTANT NOTE

1. Concrete pad should be 150mm thick on a suitably compacted foundation. IMPORTANT - pad must be flat and level.
2. The concrete to be minimum 20 mpa, cured for seven days.
3. Hold down anchors to be minimum M10 x 125 (qty 4) and M10 x 75mm (qty 3).  
Minimum 75mm depth into the concrete pad.

# DOUBLE F21 TURNSTILE

## IMPORTANT NOTE

1. Concrete pad should be 150mm thick on a suitably compacted foundation. IMPORTANT - pad must be flat and level.
2. The concrete to be minimum 20 mpa, cured for seven days.
3. Hold down anchors to be minimum M10 x 125 (qty 4) and M10 x 75mm (qty 3). Minimum 75mm depth into the concrete pad.

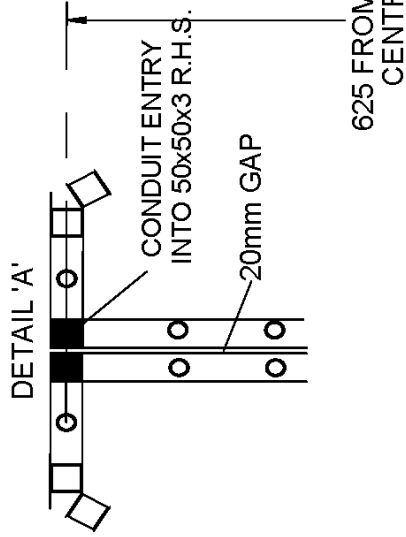

## STANDARD

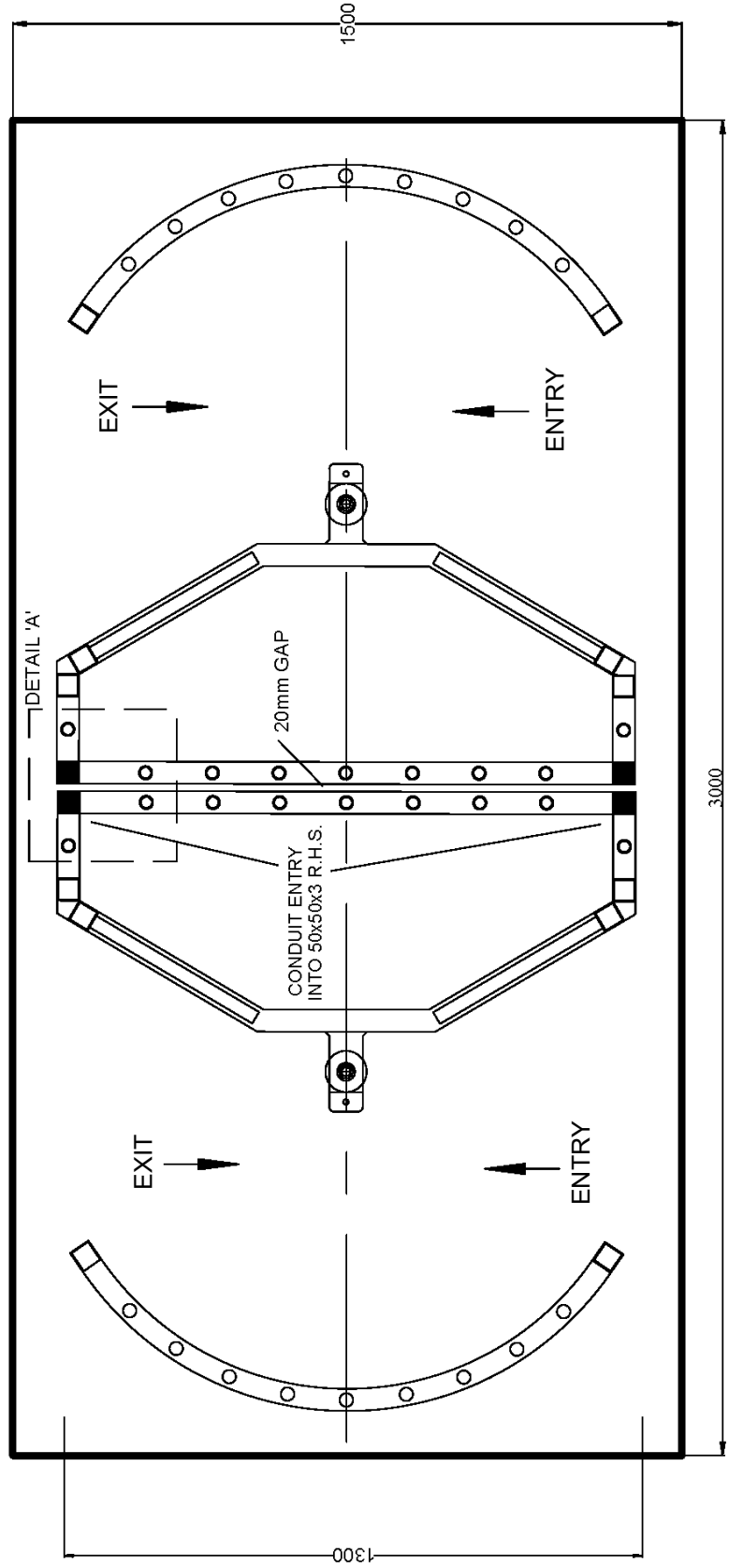

## NON-STANDARD

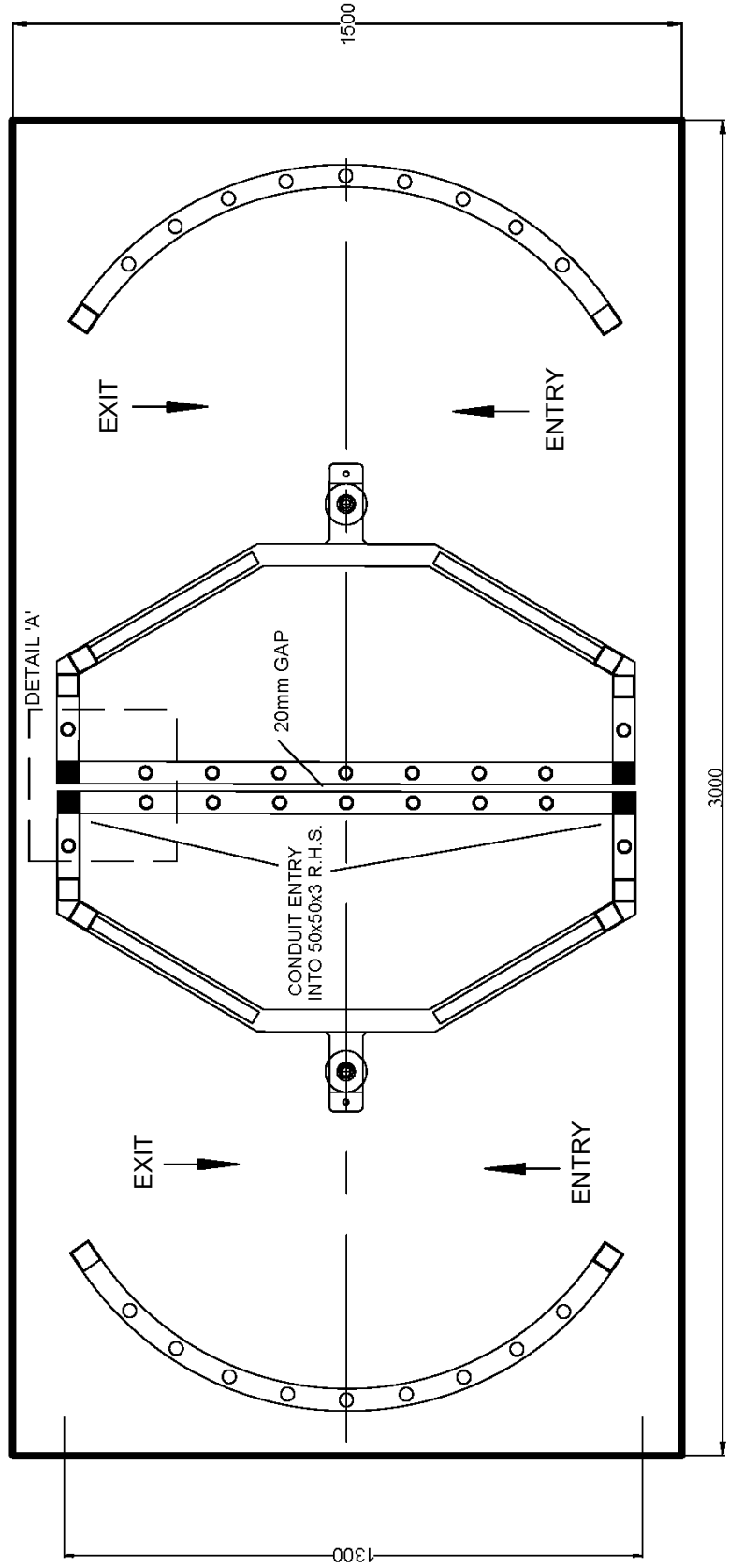

## Service Instructions

F21 turnstiles are designed for minimum maintenance during their service life. The header box lids are fitted with rubber seals to ensure a dust free interior.

**NOTE : The lid must be secured at all times and not left open.**

1. **SOLENOIDS:** These have hard chromed armatures running in PTFE bushes and are designed to operate dry.  
**DO NOT GREASE OR OIL** as this could accumulate dust and damage the surface on the armature.  
The master links between the solenoids and the pawl require a light grease on the shafts when doing the locking roller servicing every 2 years.
2. **LOCKING PAWLS AND LOCKING ROLLERS:** These need to be cleaned and greased approximately every 2 years, depending on the traffic flow through the turnstile.
3. **HEAD:** The locking drum is supported by two sealed ball bearings that do not need any servicing.
4. **CLEANING:**
  - Remove the limit cam fitted on the top of the main shaft protruding through the top plate
  - Remove the 3 nuts holding the top plate down
  - Lift the top plate off, lift the roller pins out with the rollers, wash and inspect for wear  
Re-lubricate with grease and refit.
  - Clean the pivot bushes on the pawls, re-grease and refit.
  - When re placing the top plate, ensure the spindle is in the default position.
  - Re-fit and tighten 3 hold-down bolts.
  - Re-fit limit cam to main shaft.
5. **BATTERIES:** The batteries are rated for 10 years life but we suggest that you replace them every 2 years.