

Sentinel 200mm Traffic Lights

200 mm red/green traffic lights

Standard traffic lights that are used on Australian roads are all normally 200 mm in diameter and need to be visible at distances of up to 300 metres.

In some circumstances a smaller traffic light with a narrower viewing angle and a lower light intensity is required. The 100 mm diameter is ideal for this application.



200 mm Red / Green Traffic Light

In most access control situations the two aspect red / green combination is used.

All the Sentinel Traffic Lights are suitable for harsh conditions and are supplied in a waterproof ABS plastic enclosure with adjustable mounting brackets.

The low voltage controls eliminate the need for expensive cable runs of mains power.

Ramp Control Board Option

For applications where smooth traffic flow and/or high safety is a factor the Sentinel traffic lights can be incorporated as part of a total traffic management solution with our ramp controller option.

Whether you need a combination of traffic lights, loop detectors, radar systems to work in conjunction with your boom gate/s we can provide a ramp controller board with the functionality configured specifically to suit your traffic control needs. Please contact us for a detailed quote.

Technical Specifications

Specification	Sentinel Traffic Lights
Lens Size	200mm
Colour	Red / Green
Light Intensity	Red ≥ 400 cd Green ≥ 400 cd
Temperature	-40°C to + 80°C
Protection	IP55
Voltage	24Vdc or 240VAC versions available
Housing Material	Polycarbonate
Life Span	$\geq 70\ 000$ hrs
Weight	6 kg
Viewing Angle	45°

Dimensions

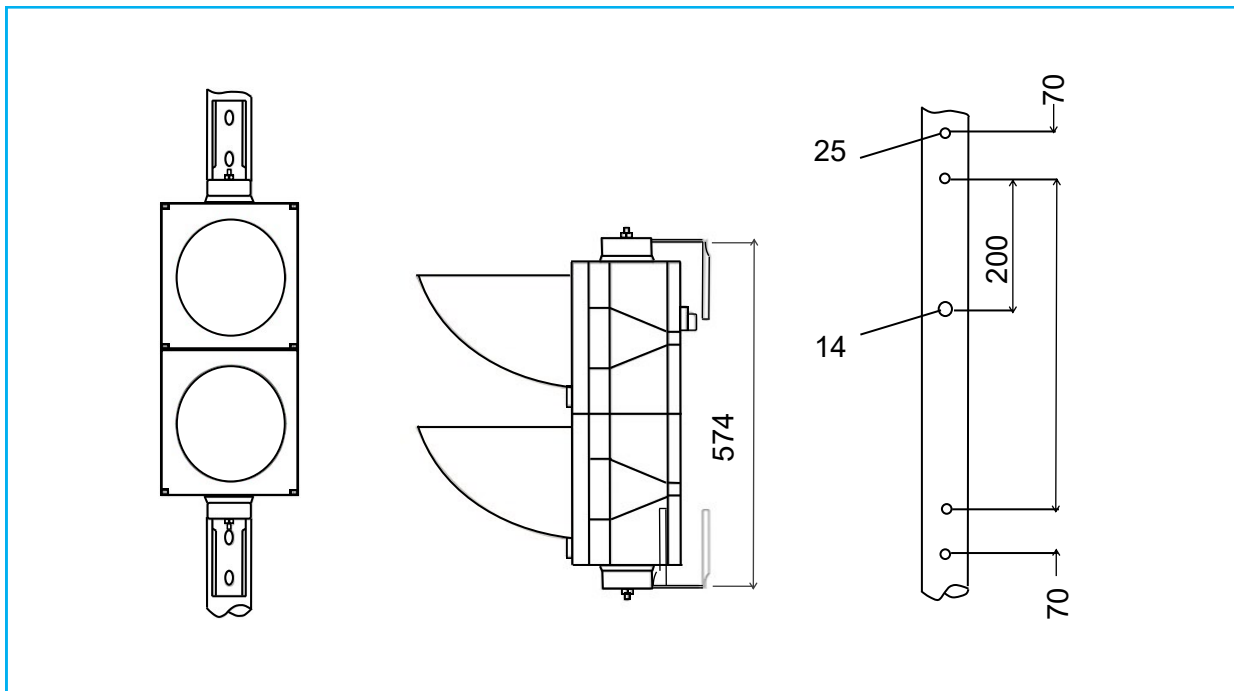

Rotech supply all forms of door and gate automation

Vehicle Access Control

- Booms Gates
- Sliding Gates
- Swing Gates
- Industrial Door Openers
- Solar Powered Gate Openers

Pedestrian Access Control

- Full Height Turnstiles
- Waist Height Turnstiles
- Supermarket Gates/Turnstiles
- Wheelchair Access Gates
- Rapid Access Gates

Fast | Safe | Secure