



Vehicle Access Control
Pedestrian Access Control
Safety & Security Equipment

t: +61 07 3205 1123

www.rotech.com.au

e: info@rotech.com.au

PE BEAMS HARD WIRED 40 MT INSTALLATION OPERATING AND INSTALLATION INSTRUCTIONS

FTC 920/960

TX



RX



FERPORT S.a.s. is not liable for damages due to incorrect connections and/or tampering of the receivers neither are such damages covered by guarantee.

Model FTC 920/960 is a registered trademark of **FERPORT S.a.s.** Such devices and all its parts are protected according to the existing laws. No part of this guide may be reproduced without the prior written permission of **FERPORT S.a.s.** The connections to the terminal board are to be carried out by qualified people after having read the above mentioned instructions.

NB: An omnipolar switch is required in the terminal with contacts having a minimum distance of 3 mm, in order to switch it off before servicing (CEI 64-8).

PHOTOCELLE RX

RX 920



SENSOR IR



SENSOR IR

RX 960

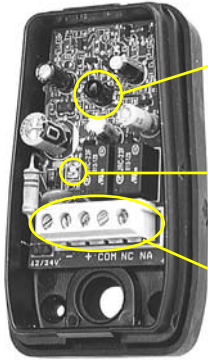

POSITIONING SIGNAL LED

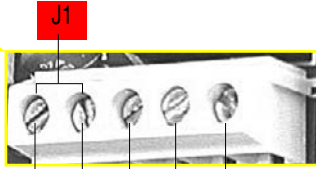
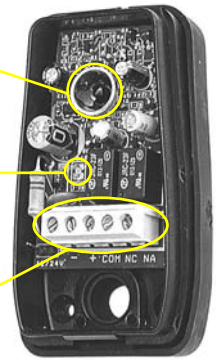

J1



- | | | | |
|---|----------------------------|----|--|
| 1 | 12V dc/24V ac/dc - feeding | 4 | nc |
| 2 | 12V dc/24V ac/dc + feeding | 5 | no |
| 3 | Common contact | J1 | 24V open connection
12V closed connection |

ENGLISH

PHOTOCELLE TX

TX 920



TRANSMITTER IR



POSITIONING SIGNAL LED



J1

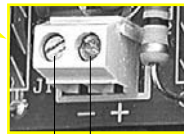

1 2



TRANSMITTER IR



POSITIONING SIGNAL LED



J1

- | | |
|---|----------------------------|
| 1 | 12V dc/24V ac/dc - feeding |
| 2 | 12V dc/24V ac/dc + feeding |

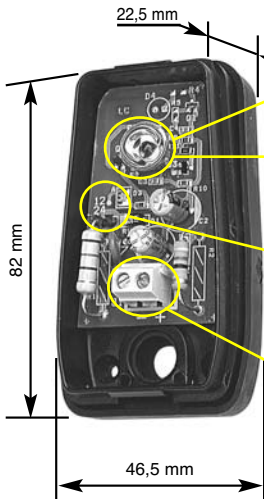

TX 960

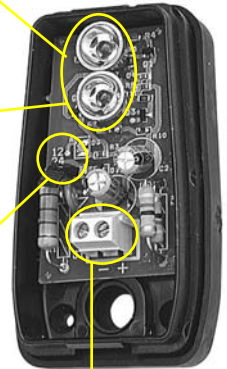

TECHNICAL SPECIFICATIONS

- 12V ac/24V ac/dc feeding
- Absorption: 108mA a 24V ac
- Positioning signal led on receiver
- Feeding signal led on receiver
- Condense resistance on TX and RX
 - 20 mts. maximum working distance (Mod. FTC920) optimal condition
 - 60 mts. maximum working distance (Mod. FTC960)
- Infrared emission with constant modulation: 1,33 KHz
- Emission wavelength: 950 nM
- Max power commutable 1A a 24V ac
- IP55 Protection degree

SETTING AND ADJUSTING INSTRUCTION

Fix the external shells of the photo-cells on the concrete wall or on the metallic support. The distance from the ground must be about 40-60 cm and 10 cm maximum from the external line of the gate.

The correct distance in other case referred to photo-cells installed on leaf gates must be measured from the open position or after mechanical strips.

Photo-cells are centering by themselves.

We suggest to install them on the same axis, to obtain a correct working without mistakes.

ENGLISH

GASKET AND PRESSWIRE INSTRUCTION OF ASSEMBLY

Install the o-ring gasket in the wire support on the sight photo-cell, control the right horizontal position on the upper side of the sight. Assure the two side of the gasket up to 15 mm on the both faces.

After this operation press the two shells towards themselves and control the perfect closing line before installing the electrical wire inside of the box of photo-cell, a smaller hole with thin diameter respect to the electric wire.

Will be drilled on the back cap.

General warnings: only authorised and good trained personal may operate on our plants.

N.B. Front with receiver lens

Front without transmitter lens.

INSTALLATION DIAGRAM

COLUMN MOUNT

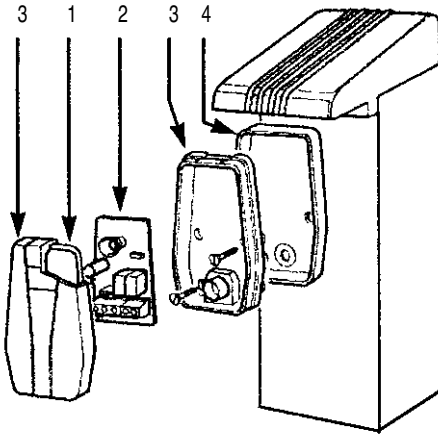

MOUNT WITH AD 90

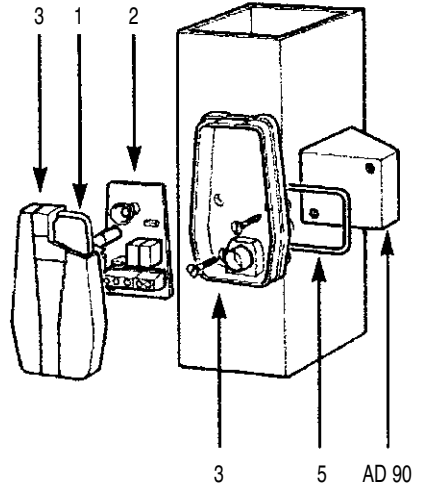

JOINT MOUNT

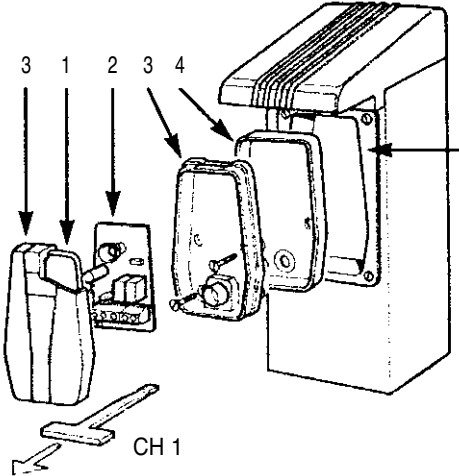

MOUNT WITH AD 60

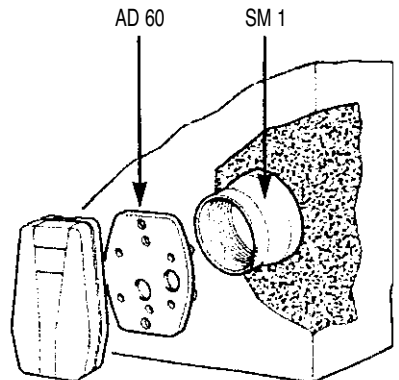

- 1) O-ring
- 2) Electronics
- 3) Container
- 4) Rubber seal
- 5) O-ring

CH1 Key for removing the front glass

ENGLISH